

EINZELBETT

BODENSTEHENDES KOPFTEIL

LIT SIMPLE

TÊTE DE LIT POSÉE AU SOL

EÉNPERSOONSBED

MET STAAND HOOFDBORD

SINGLE BED

FLOORSTANDING HEADBOARD

MOTOR BOX CUBIC

120-140 CM

BOXSPRING

# MOTOR BOX CUBIC 120-140cm

Montageschritte sind nach Fußvarianten ausgerichtet // Les opérations de montage sont décrites en fonction des variantes de pieds  
 Montagestappen geranschikt per pootvariant // Assembly steps sorted per leg version

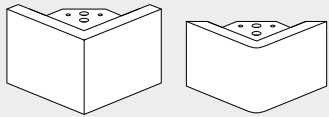

L-FUSS // ROBUST ECHTHOLZ WENGE // METALLFUSS RUND  
 METALLFUSS ECKIG // **SEITE 3**

PIEDS L // BOIS MASSIF WENGÉ VÉRITABLE // PIED MÉTAL ROND  
 PIED MÉTAL CARRÉ / **PAGE 3**

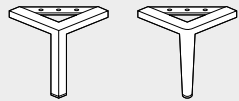

WOOD CUBUS // METAL ROUND  
 METAL SQUARE // **PAGE 3/PAGINA 3**

L-LEG // ROBUST WOOD WENGE // METALLEG ROUND  
 METALLEG SQUARE // **PAGE 3**

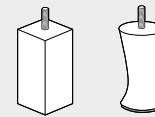

HOLZFUSS GERADE // HOLZFUSS SCHRÄG //  
 HOLZFUSS ECKIG // CHAMPAGNERFUSS // **SEITE 11**

PIED BOIS DROIT // PIED BOIS CONIQUE  
 PIED BOIS CARRÉ // PIED CHAMPAGNE // **PAGE 11**

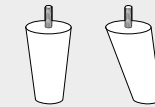

WOOD ROUND // WOOD OBLIC // WOOD SQUARE  
**PAGE 11/PAGINA 11**

WOOD LEG STRAIGHT // WOOD LEG SPLAYED  
 WOOD LEG SQUARE // CHAMPAGNER LEG // **PAGE 11**

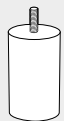

SCHWEBEOPTIK // **SEITE 14**  
 ASPECT FLOTTANTE // **PAGE 14**  
 ZWEVEND // **PAGE 14/PAGINA 14**  
 FLOATING LOOK // **PAGE 14**

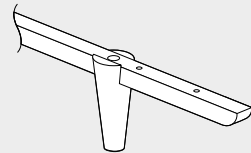

HOLZLEISTE VORNE // **SEITE 17**  
 TRAVERSE EN BOIS, AVANT // **PAGE 17**  
 WOOD BEAM **PAGE 17/PAGINA 17**  
 WOODEN FRONT BEAM // **PAGE 17**

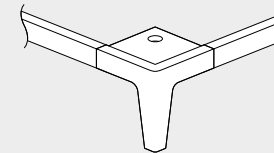

HOLZRAHMEN GESAMT // **SEITE 21**  
 CADRE BOIS TOTAL // **PAGE 21**  
 WOOD FRAME VOLLEDIG // **PAGE 21/PAGINA 21**  
 WOODEN FRAME COMPLETE // **PAGE 21**

NOTABSENKUNG  
**SEITE 26**

ABAISSEMENT D'URGENCE  
**PAGE 26**

NOODDAALFUNCTIE  
**PAGE 26/PAGINA 26**

EMERGENCY LOWERING  
**PAGE 28**

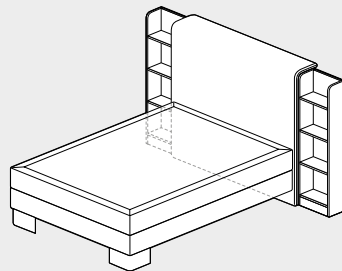

KOPFTEIL MIT REGALEN  
**SEITE 28**

TÊTE DE LIT AVEC ÉTAGÈRES  
**PAGE 28**

HOOFDBORD MET WOOD SIDE  
 STORAGE  
**PAGE 28/PAGINA 28**

HEADBOARD WITH SHELVES  
**PAGE 28**

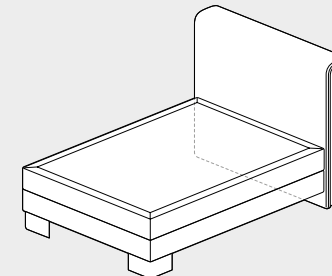

KOPFTEIL MIT SEITEN-  
 VERBLENDUNGEN  
**SEITE 30**

TÊTE DE LIT AVEC PANNEAUX  
 D'HABILLAGE LATÉRAUX  
**PAGE 30**

HOOFDBORD MET ZIJPANELEN  
**PAGE 30/PAGINA 30**

HEADBOARD WITH SIDE PANELS  
**PAGE 30**

L-FUSS // ROBUST ECHTHOLZ WENGE  
 METALLFUSS RUND // METALLFUSS ECKIG

PIEDS L // BOIS MASSIF WENGÉ VÉRITABLE  
 PIED MÉTAL ROND

WOOD CUBUS  
 METAL ROUND // METAL SQUARE

L-LEG // ROBUST WOOD WENGE  
 METALLEG ROUND // METALLEG SQUARE

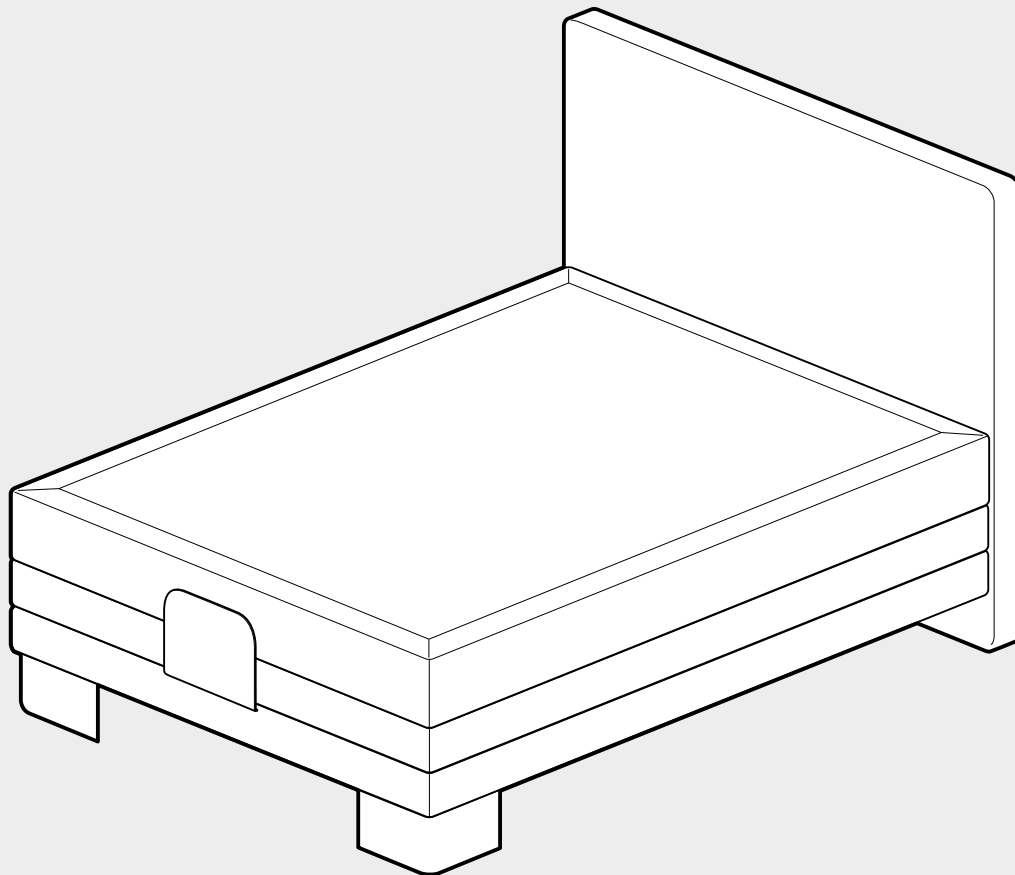

Beispielhafte Darstellung mit Fuß Robust Echtholz Wenge für gesamte „Fußgruppe“ (siehe oben)  
 Présentation schématique d'un lit avec pieds robustes en bois massif véritable (tous les pieds) (voir ci-dessus)  
 Example of bed with leg Robust wood Wenge (see above)  
 Schematische voorstelling van bed met Wood Cubus (zie hierboven)

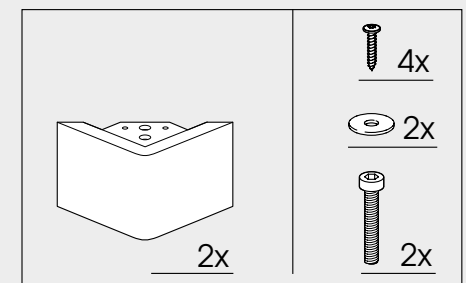
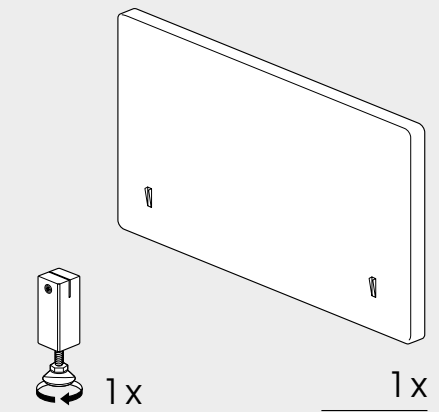
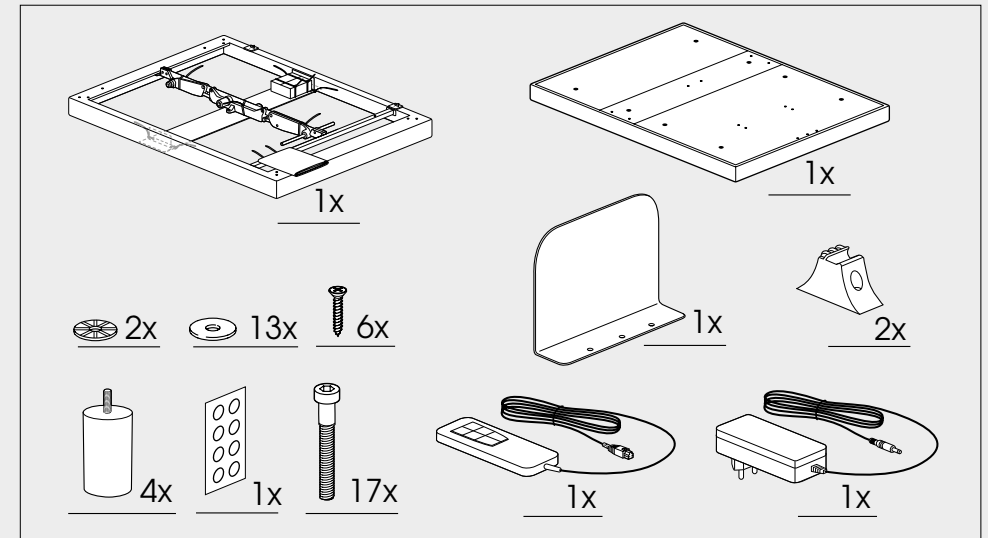

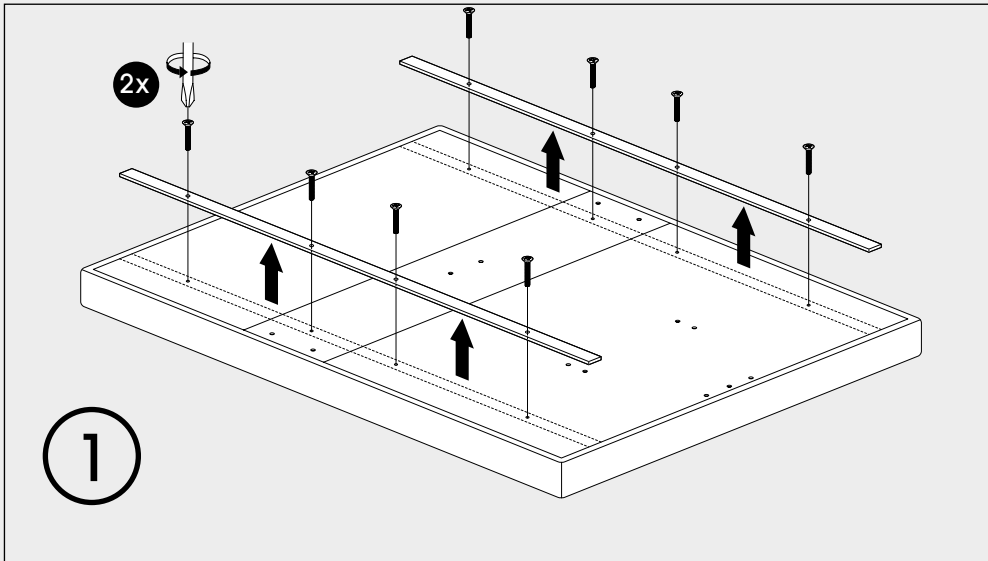

Motorbox Cubic mit einer Breite von 120 & 140cm  
 Motor Box Cubic d'une largeur de 120 & 140cm  
 Motor Box Cubic met een breedte van 120 & 140cm  
 Motor Box Cubic with a width of 120 & 140cm

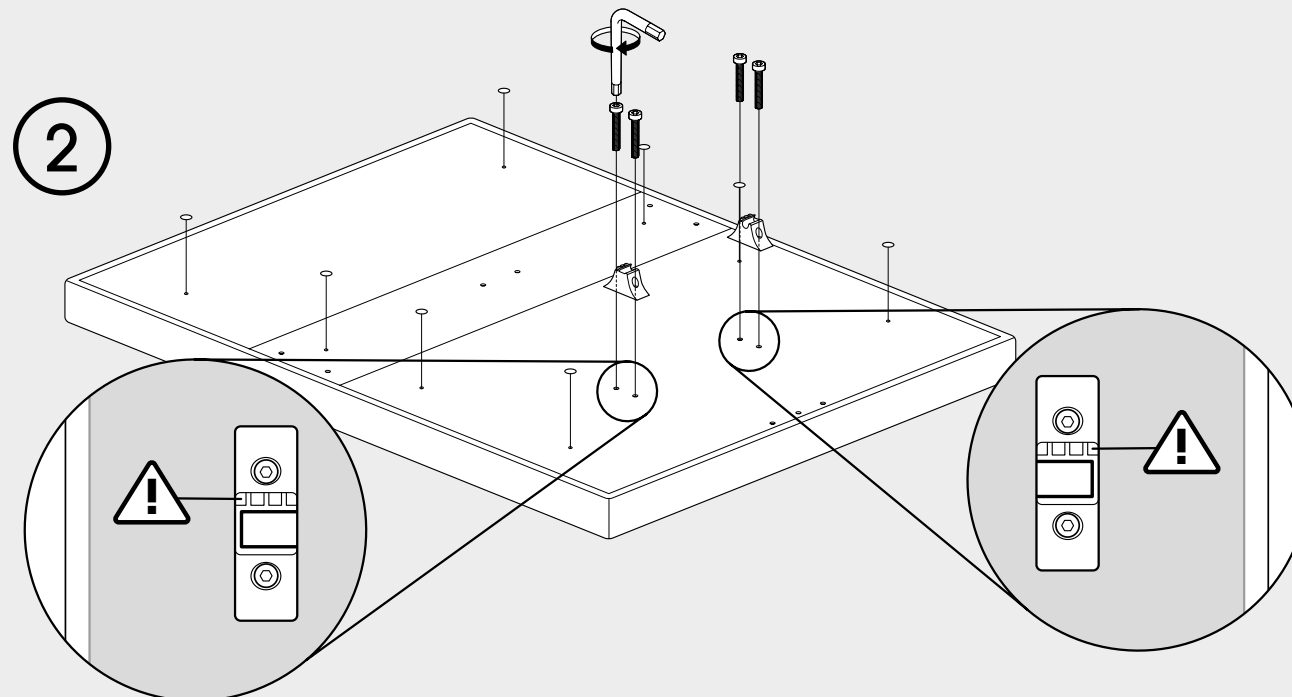

Montage der Motorbox  
 Montage du moteur  
 Montage van de motorbox  
 Assembly of the engine box

3

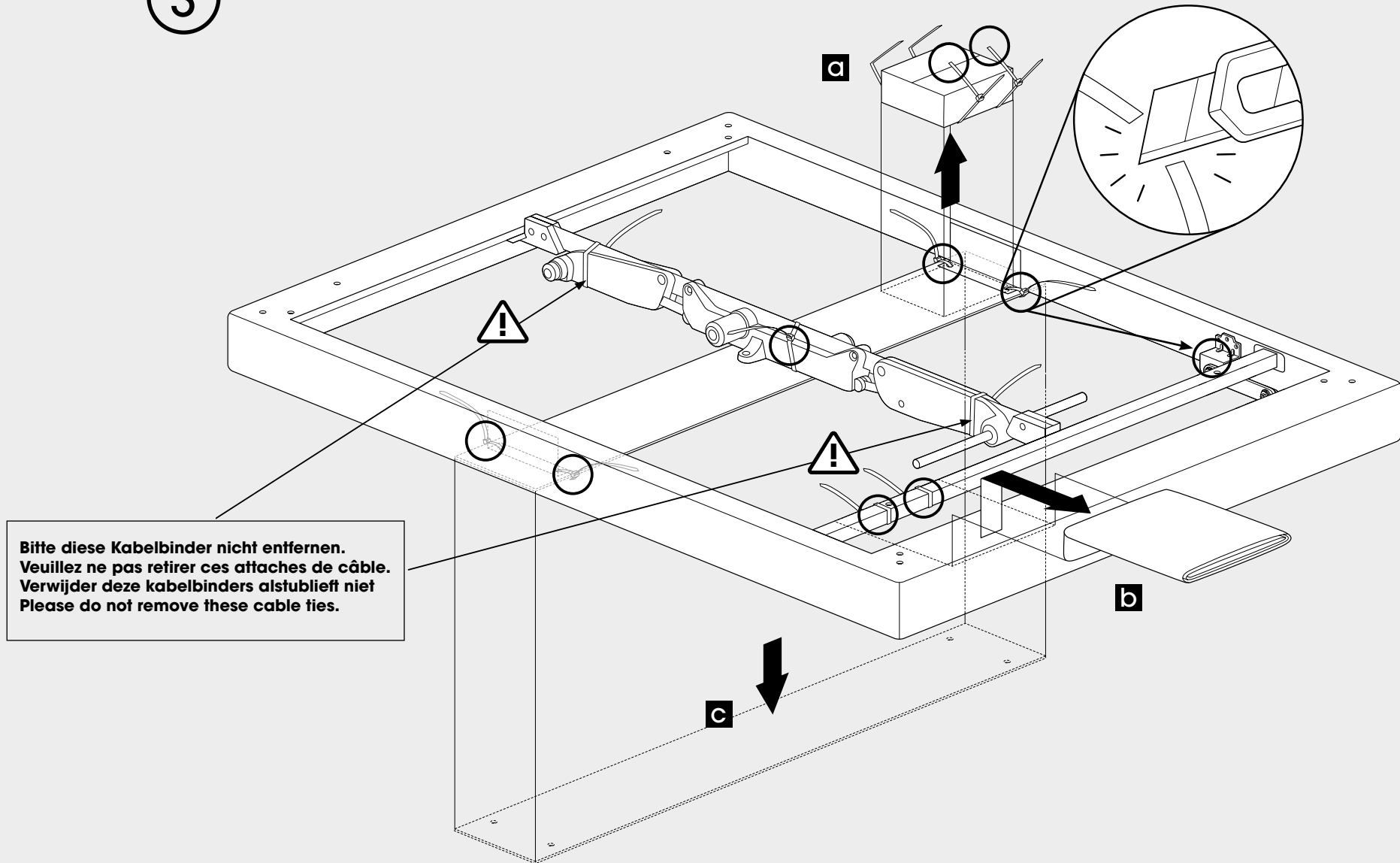

**Bitte diese Kabelbinder nicht entfernen.  
Veuillez ne pas retirer ces attaches de câble.  
Verwijder deze kabelbinders alstublieft niet  
Please do not remove these cable ties.**

Montage der Motorbox  
Montage du moteur  
Montage van de motorbox  
Assembly of the engine box

4

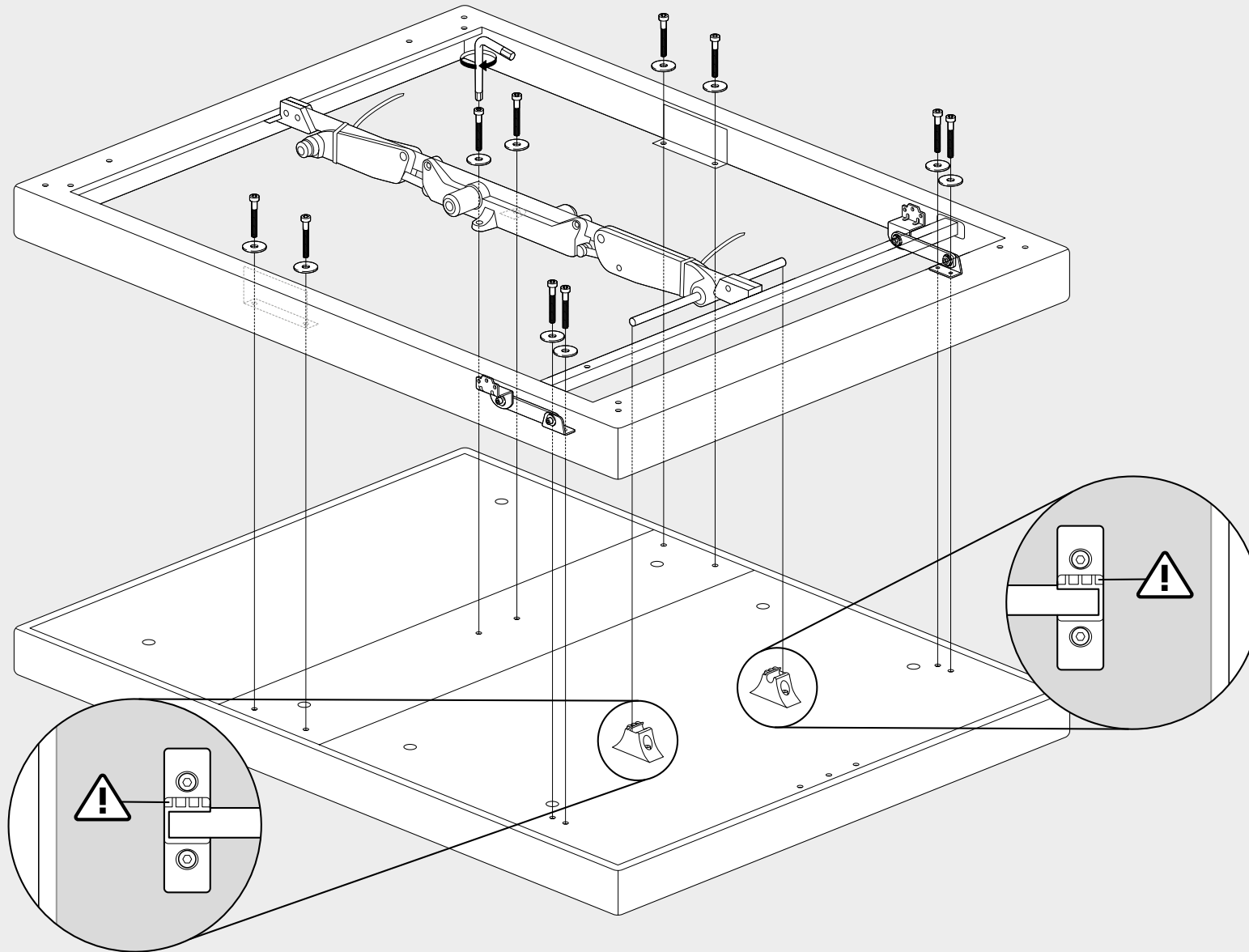

Montage der Motorbox  
Montage du moteur  
Montage van de motorbox  
Assembly of the engine box

5

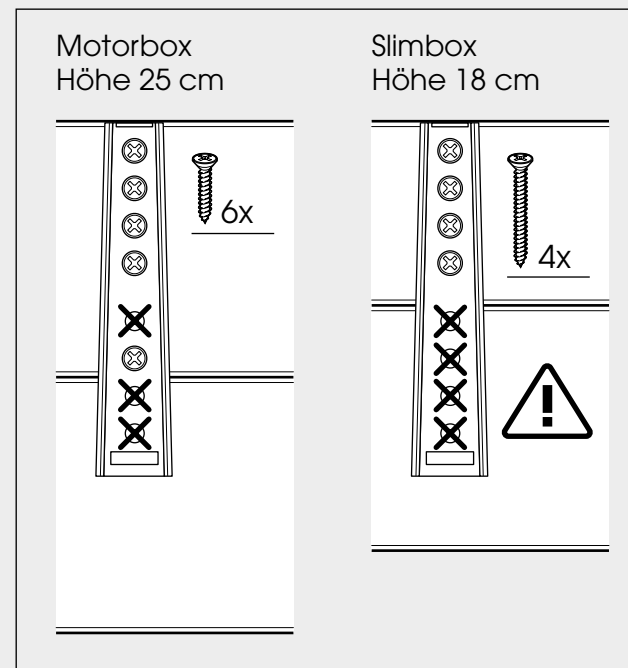
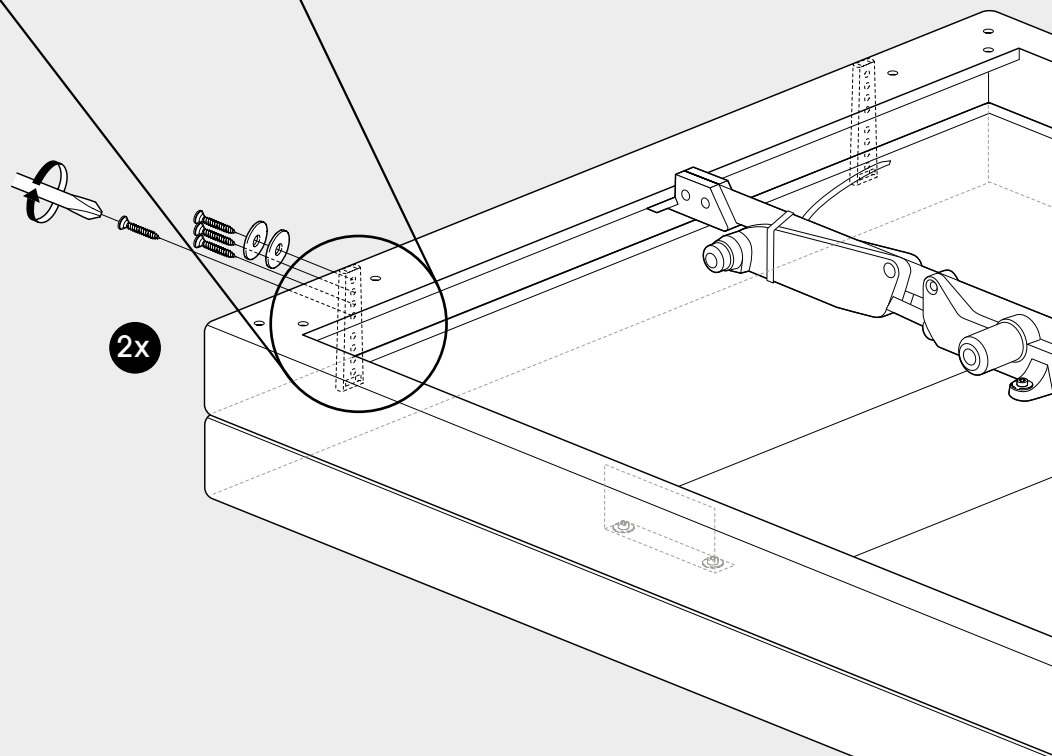
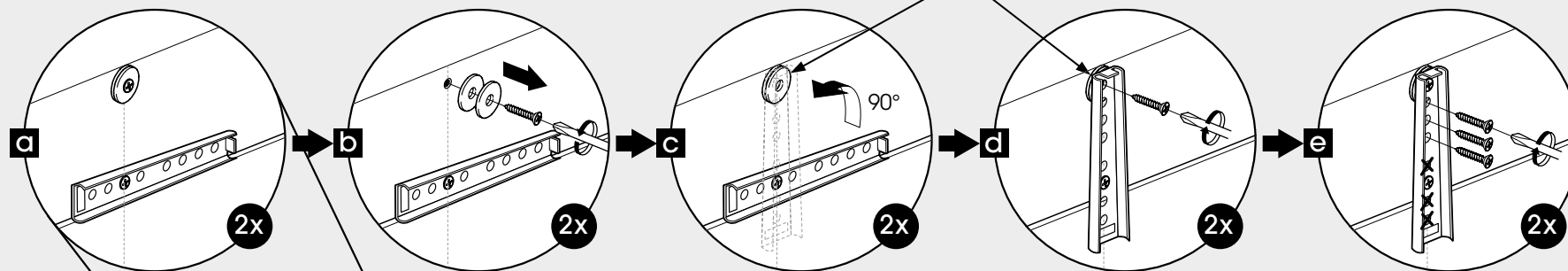

Montage der Motorbox  
Montage du monteur  
Montage van de motorbox  
Assembly of the engine box

6

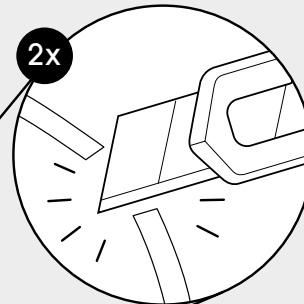
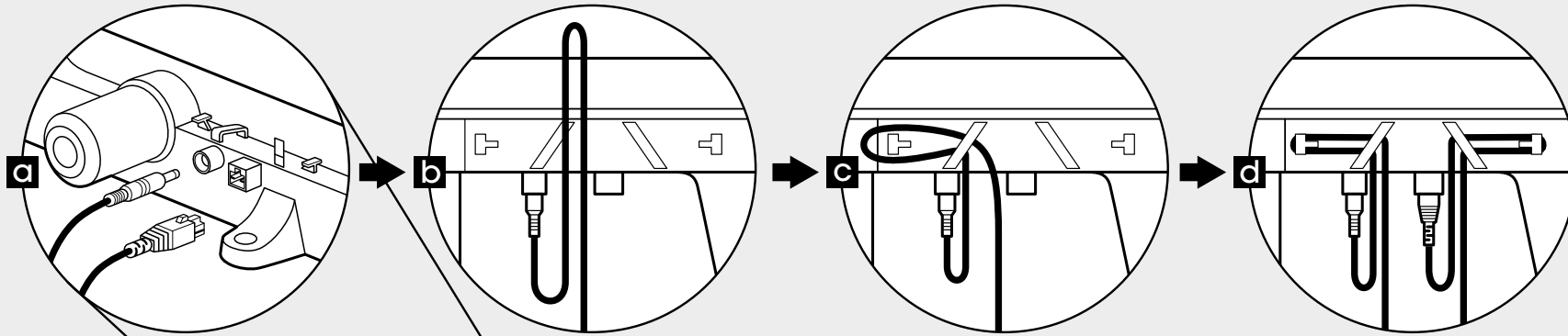

Bitte Kabelbinder entfernen  
Enlever les revettes  
Gelijke de kabelbinders te verwijderen  
Please remove zip ties

Montage der Motorbox  
Montage du moteur  
Montage van de motorbox  
Assembly of the engine box



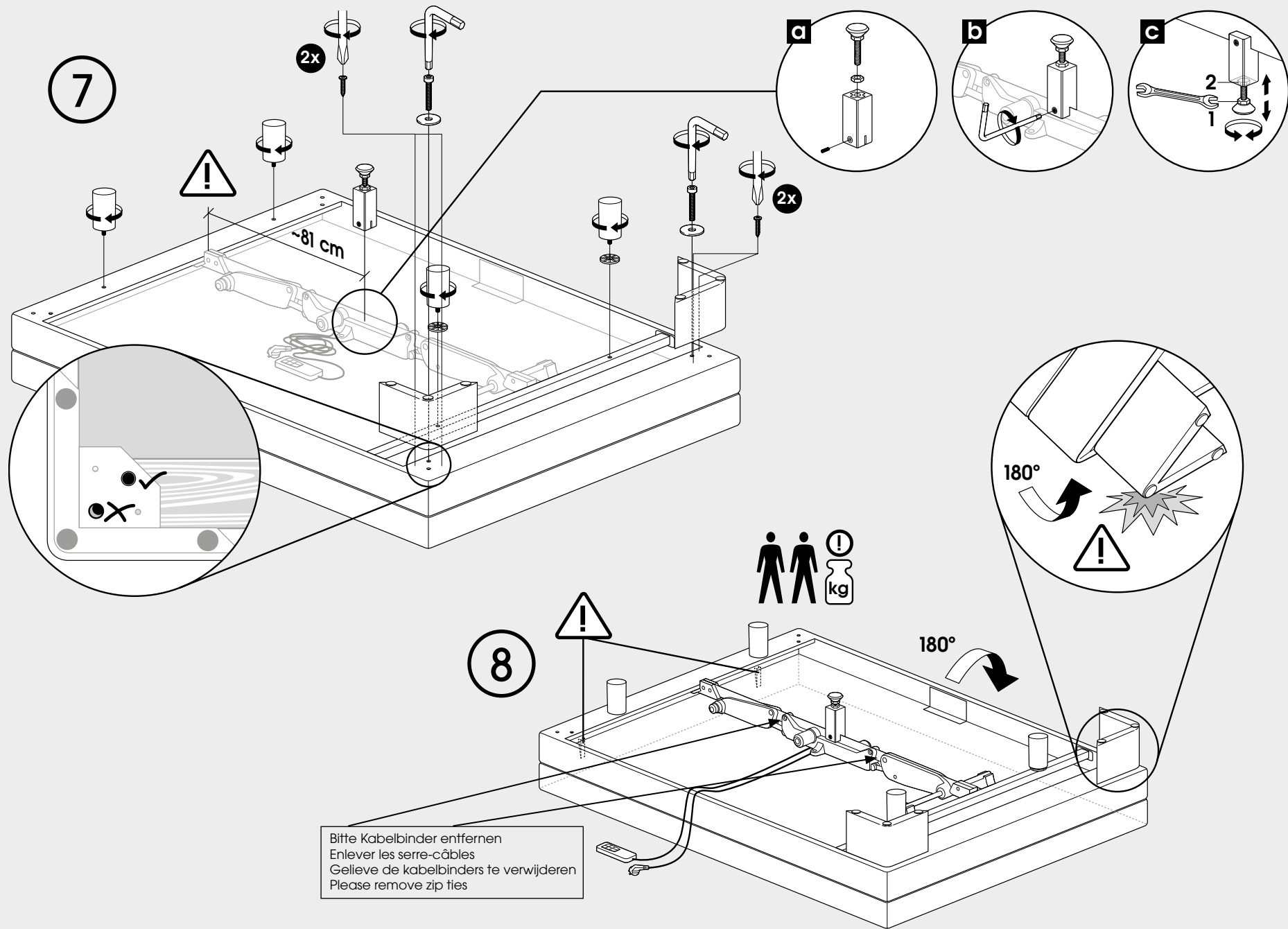

9

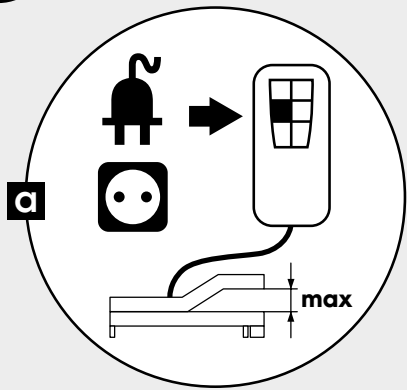

10

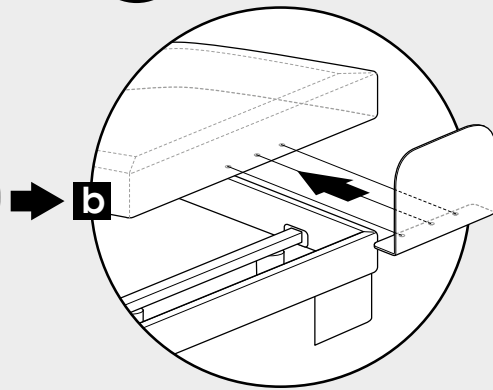

11

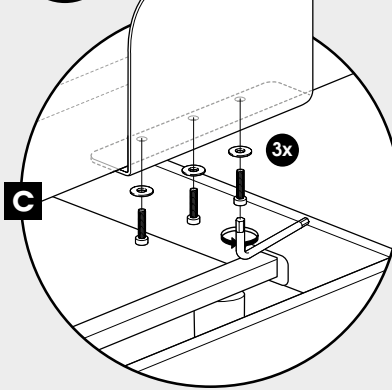

12

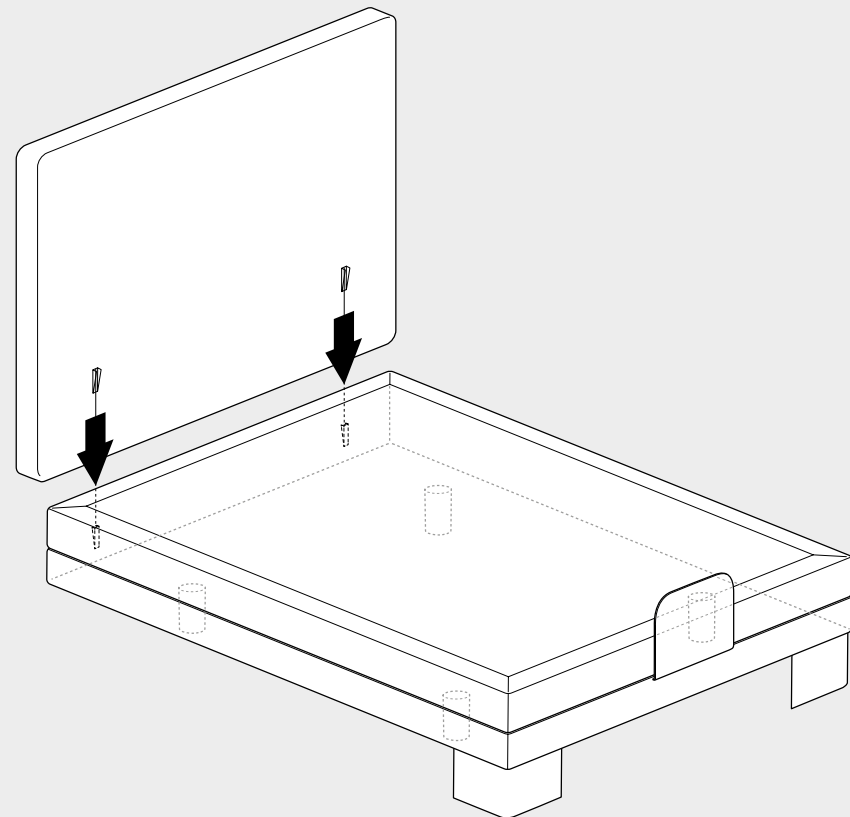

HOLZFUSS GERADE // HOLZFUSS SCHRÄG  
 HOLZFUSS ECKIG // CHAMPAGNERFUSS  
 PIED BOIS DROIT // PIED BOIS CONIQUE  
 PIED BOIS CARRÉ // PIED CHAMPAGNE

WOOD ROUND // WOOD OBLIC  
 WOOD SQUARE

WOOD LEG STRAIGHT // WOOD LEG SPLAYED  
 WOOD LEG SQUARE // CHAMPAGNER LEG

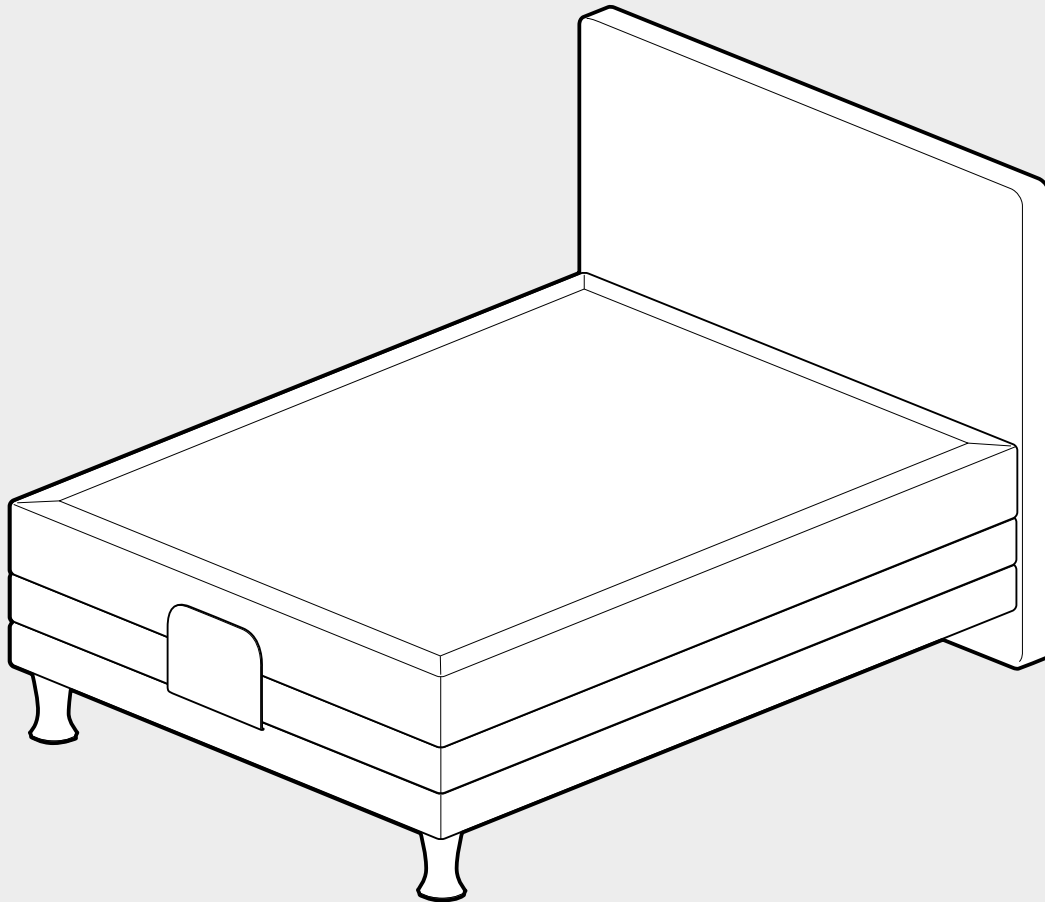

Beispielhafte Darstellung mit Champagnerfuß für gesamte „Fußgruppe“ (siehe oben)  
 Représentation schématique d'un lit avec pieds champagne (tous les pieds) (voir ci-dessus)  
 Example of bed with leg Champagner (see above)

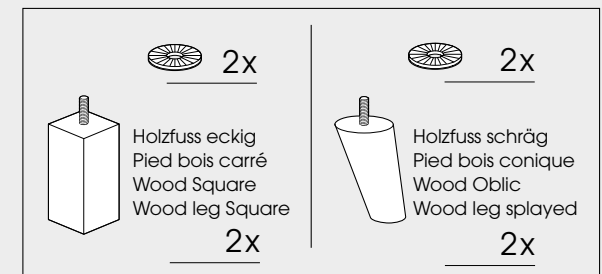
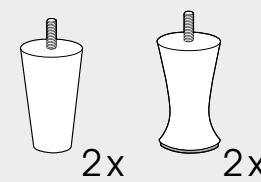
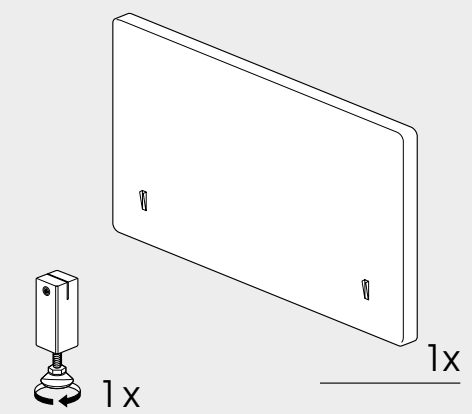
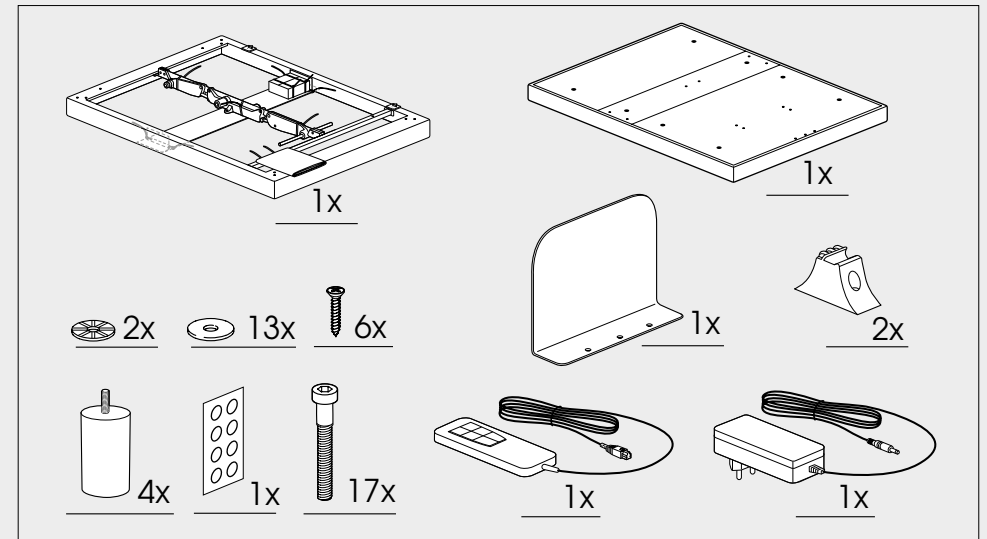

1

Bitte starten Sie mit der Montage der Motorbox analog S.4 bis S.8

Veuillez commencer par le montage du moteur analogue page 4 à page 8

Begin alsjeblieft met de montage van de motorbox analoog page 4 tot page 8

Please start with the assembly of the engine box analogue page 4 to page 8

2

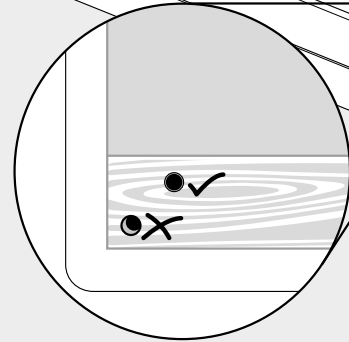
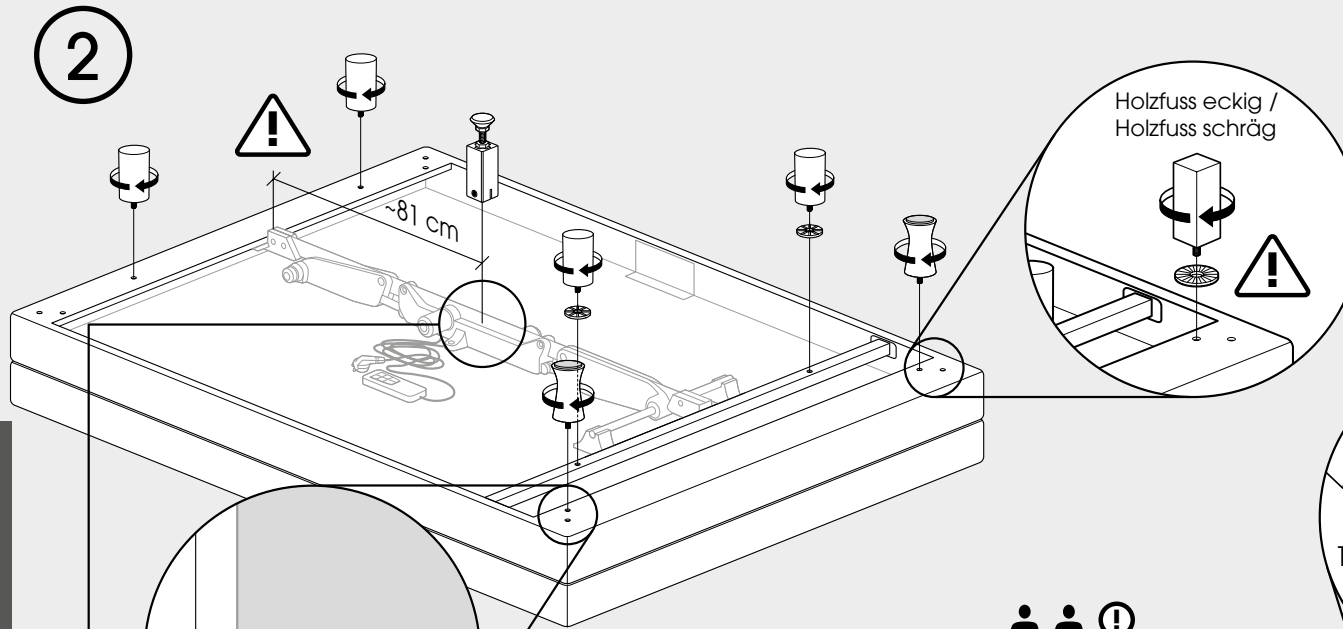

3

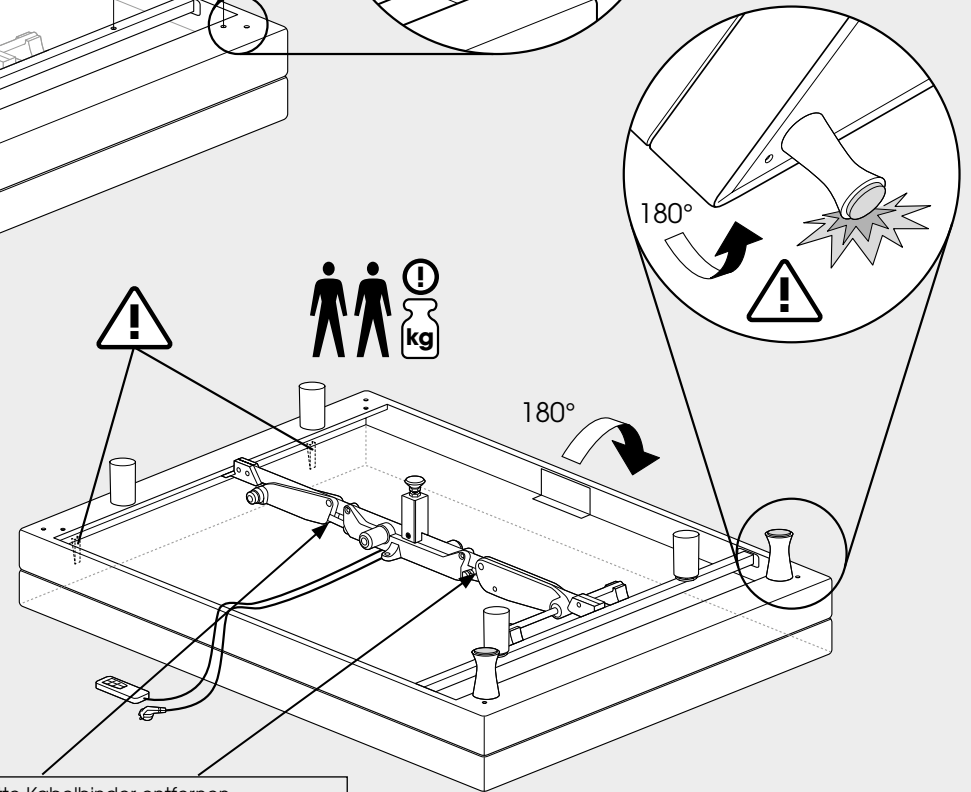
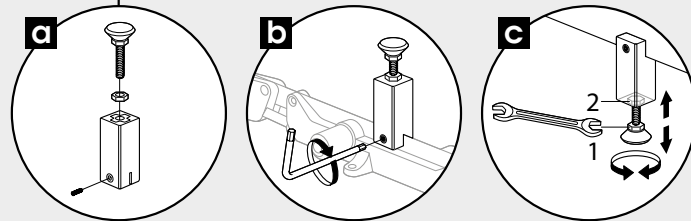

Bitte Kabelbinder entfernen  
Enlever les serre-câbles  
Gelieve de kabelbinders te verwijderen  
Please remove zip ties

HOLZFUSS GERADE // HOLZFUSS SCHRÄG // HOLZFUSS ECKIG // CHAMPAGNERFUSS  
PIED BOIS DROIT // PIED BOIS CONIQUE PIED BOIS CARRÉ // PIED CHAMPAGNE  
WOOD ROUND // WOOD OBLIC // WOOD SQUARE  
WOOD LEG STRAIGHT // WOOD LEG SPLAYED // WOOD LEG SQUARE // CHAMPAGNER LEG

4

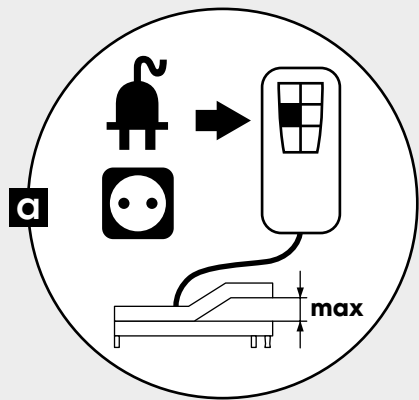

5

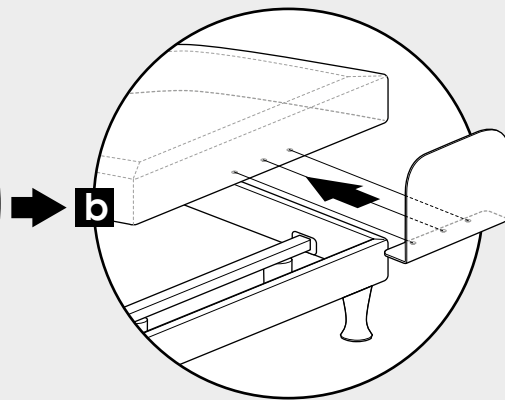

6

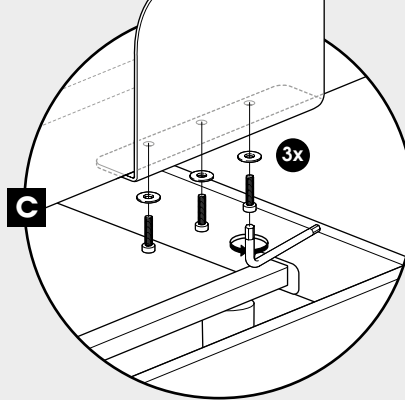

7

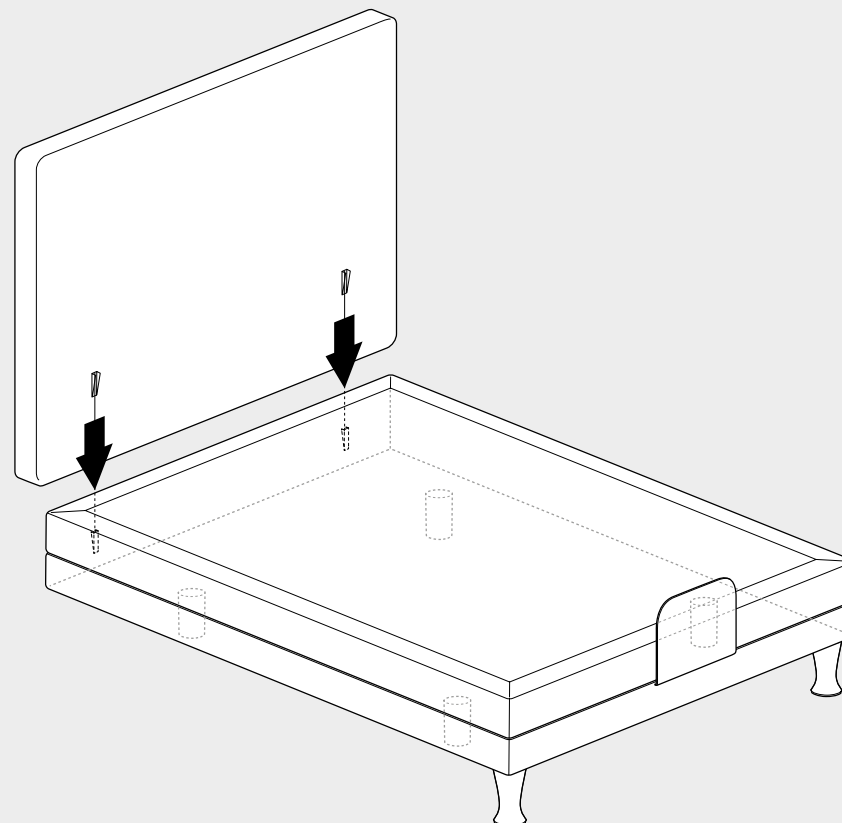

HOLZFUSS GERADE // HOLZFUSS SCHRÄG // HOLZFUSS ECKIG // CHAMPAGNERFUSS  
 PIED BOIS DROIT // PIED BOIS CONIQUE PIED BOIS CARRÉ // PIED CHAMPAGNE  
 WOOD ROUND // WOOD OBLIC // WOOD SQUARE  
 WOOD LEG STRAIGHT // WOOD LEG SPLAYED // WOOD LEG SQUARE // CHAMPAGNER LEG

SCHWEBEOPTIK  
ASPECT FLOTTANTE  
ZWEVEND  
FLOATING LOOK

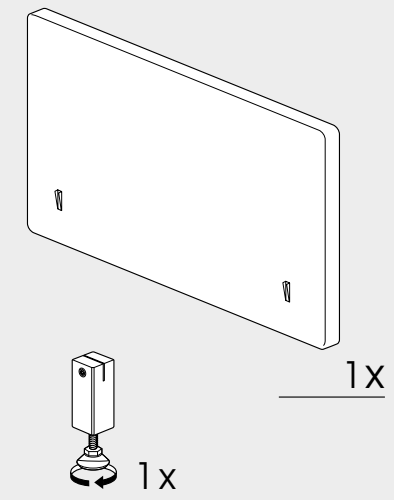
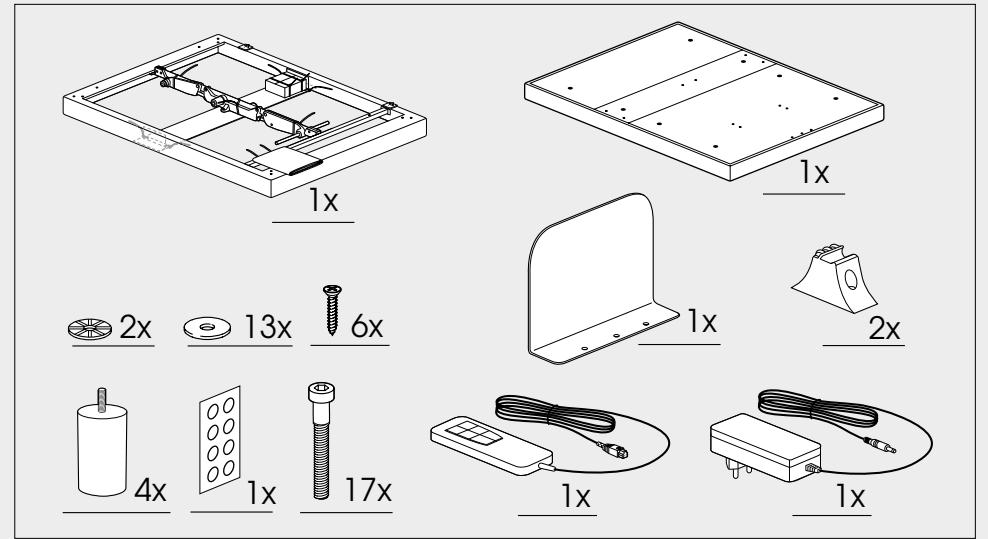
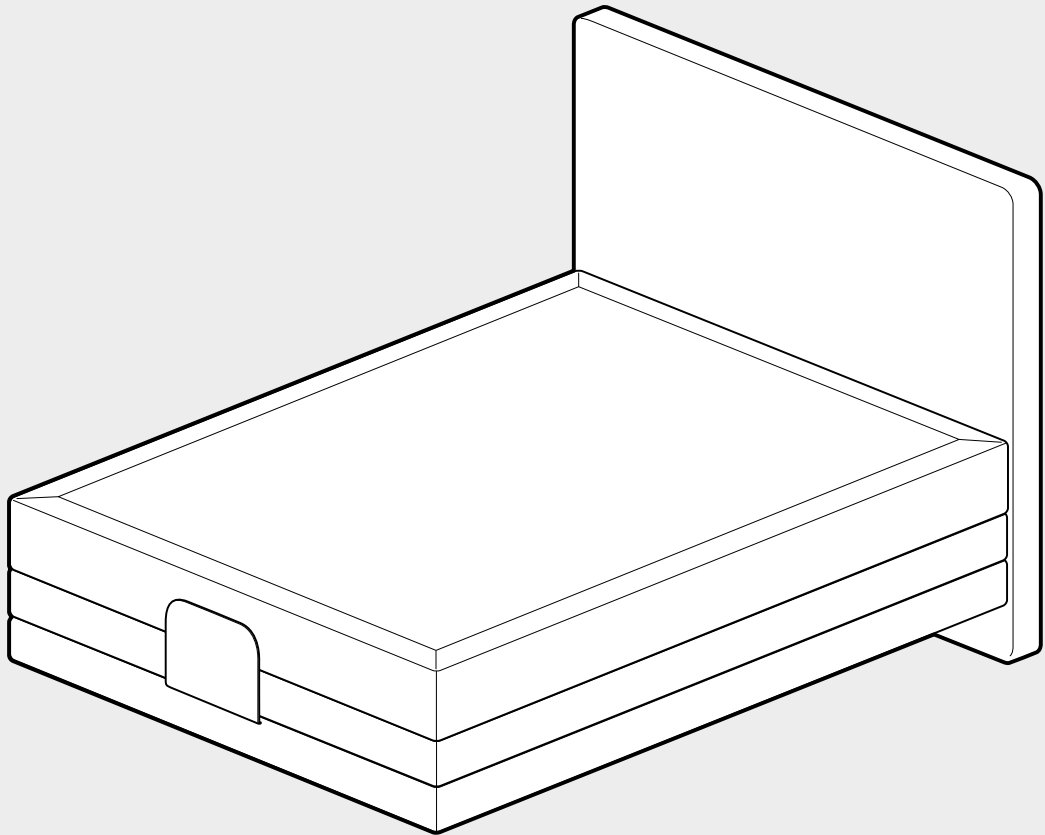

2

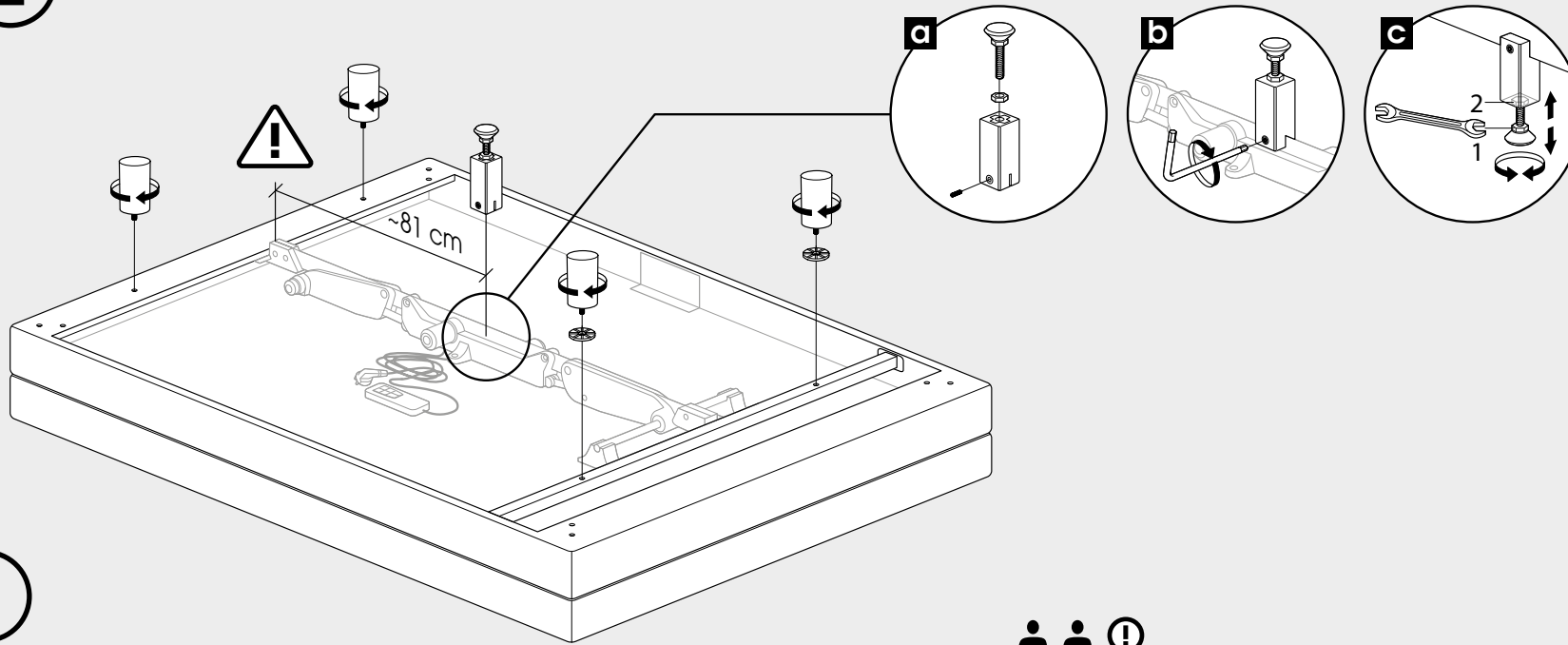

1

Bitte starten Sie mit der Montage der Motorbox analog S.4 bis S.8

Veuillez commencer par le montage du moteur analogique page 4 à page 8

Begin alsjeblieft met de montage van de motorbox analoog page 4 tot page 8

Please start with the assembly of the engine box analogue page 4 to page 8

3

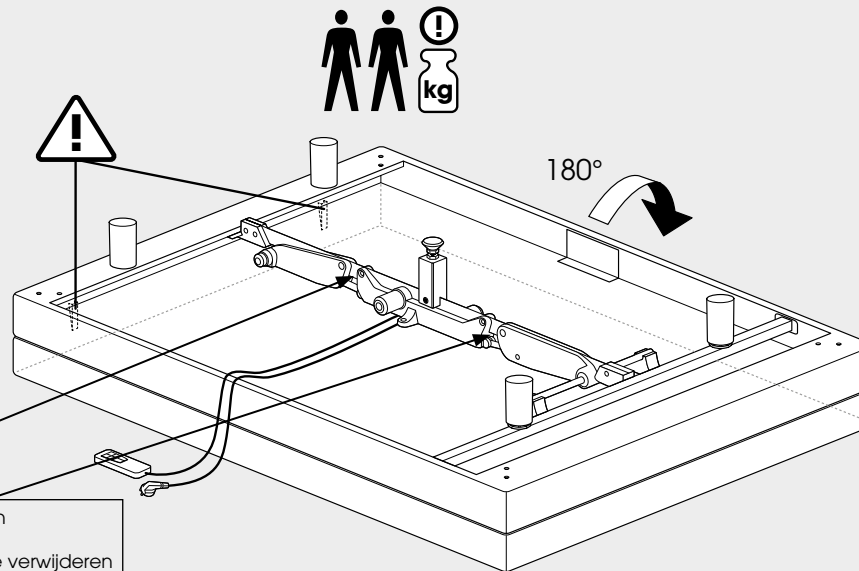

Bitte Kabelbinder entfernen  
 Enlever les serre-câbles  
 Gelieve de kabelbinders te verwijderen  
 Please remove zip ties

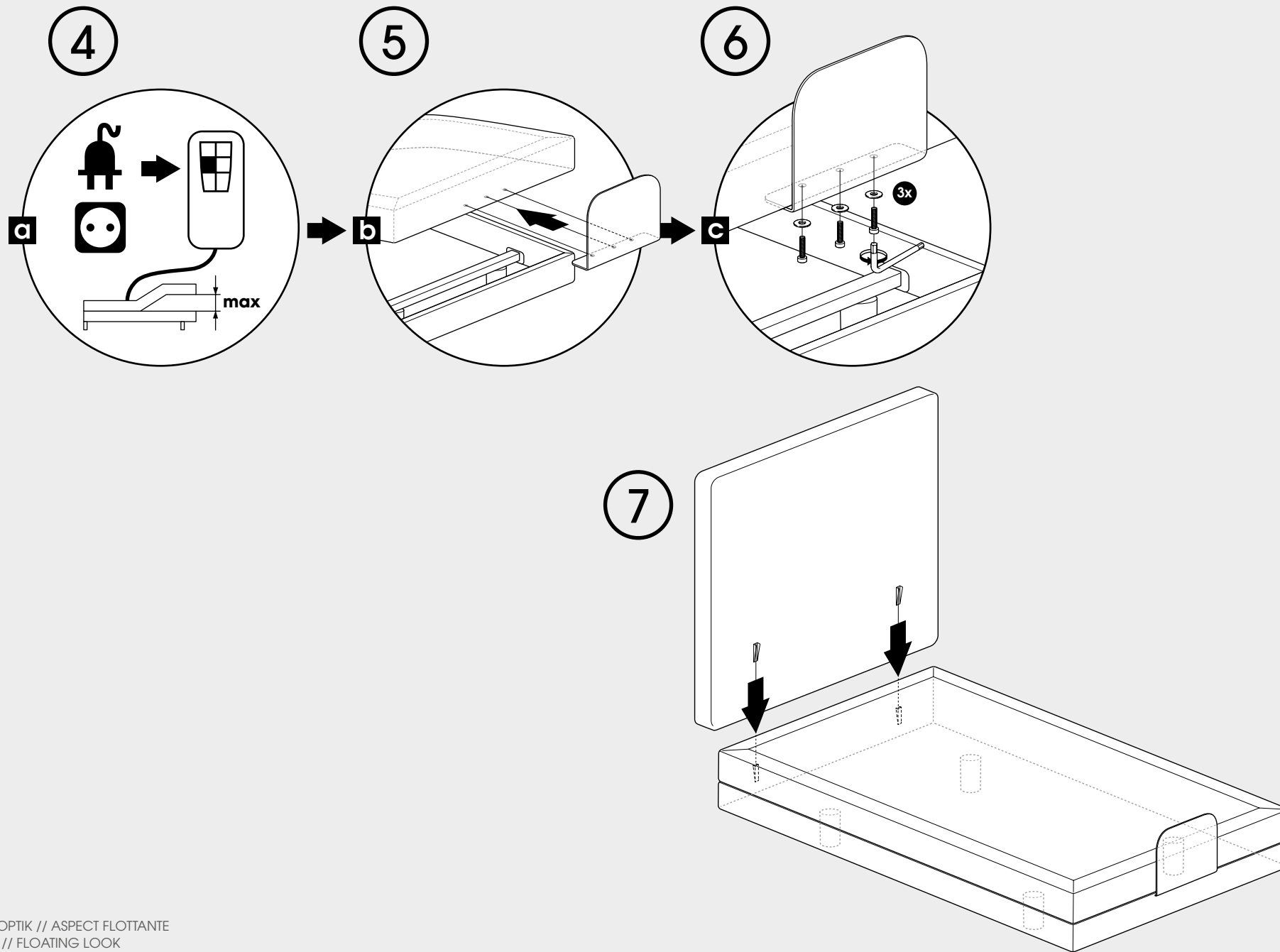



HOLZLEISTE VORNE  
 TRAVERSE EN BOIS, AVANT  
 WOOD BEAM  
 WOODEN FRONT BEAM

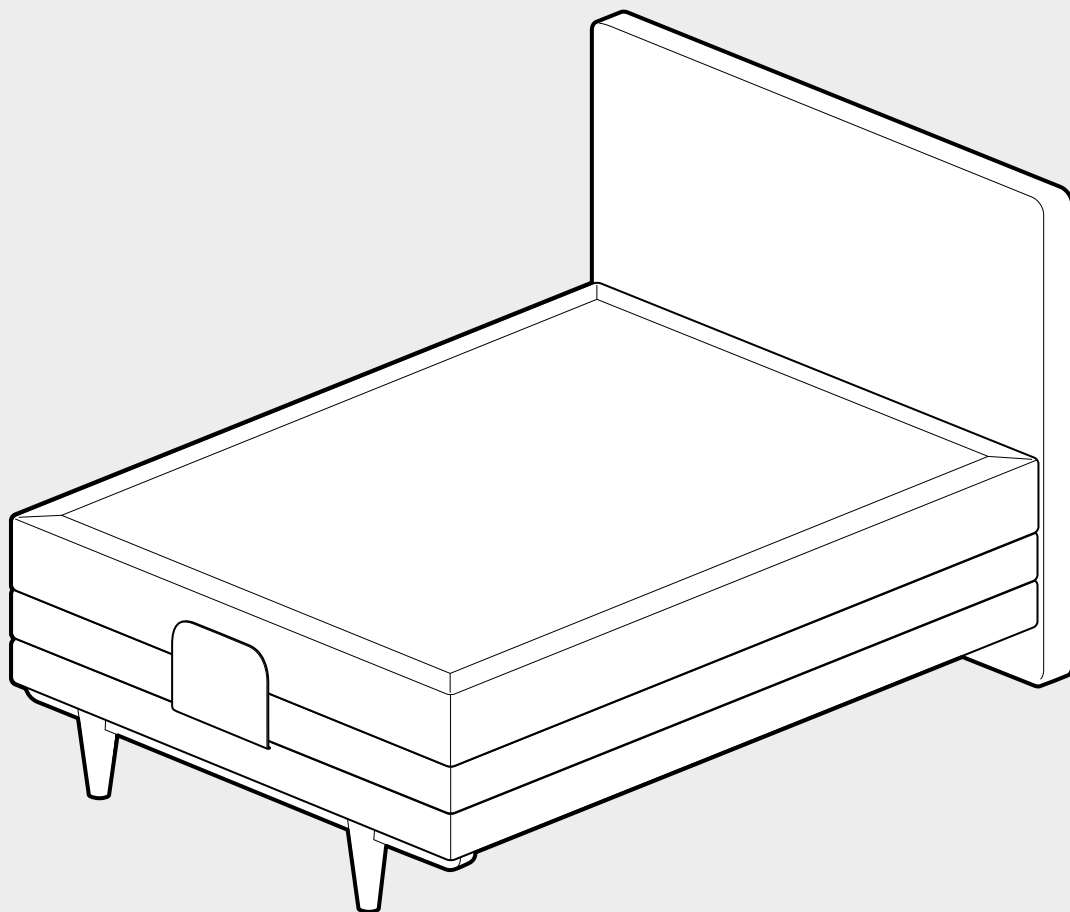

HOLZLEISTE VORNE // TRAVERSE EN BOIS, AVANT  
 WOOD BEAM // WOODEN FRONT BEAM

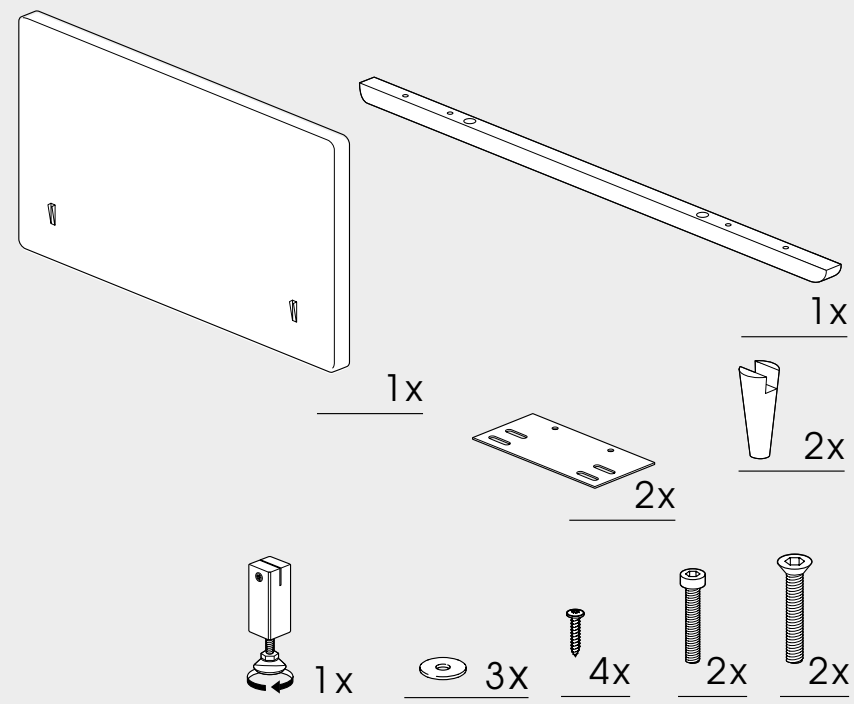
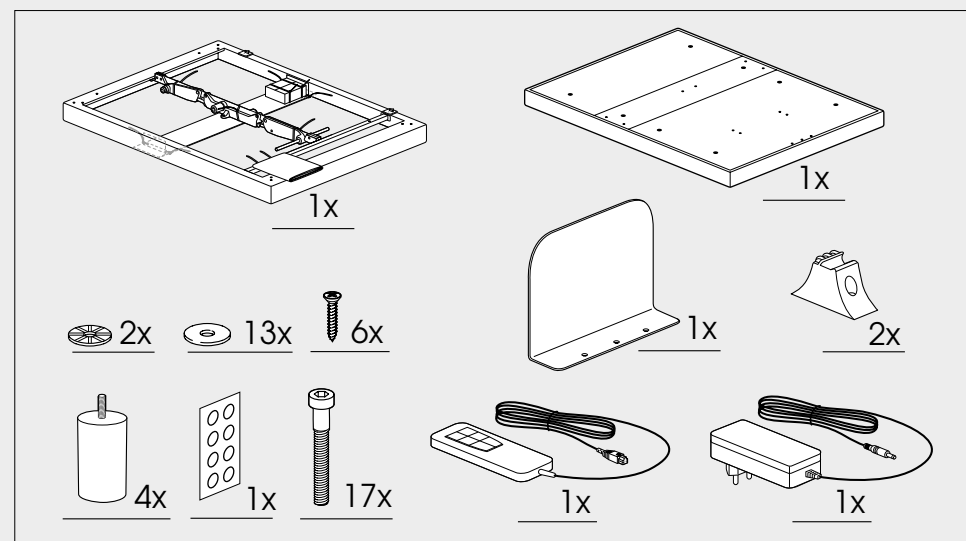

1

Bitte starten Sie mit der Montage der Motorbox analog S.4 bis S.8

Veillez commencer par le montage du moteur analogique page 4 á page 8

Begin alsjebliet met de montage van de motorbox analoog page 4 tot page 8

Please start with the assembly of the engine box analogue page 4 to page 8

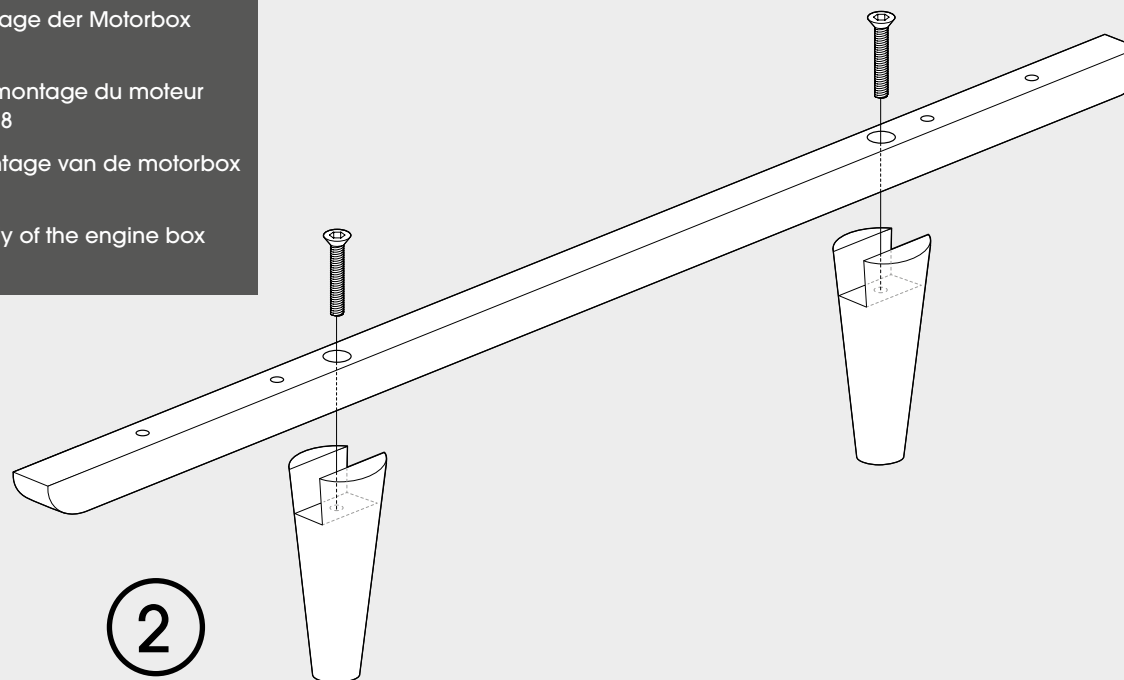

2

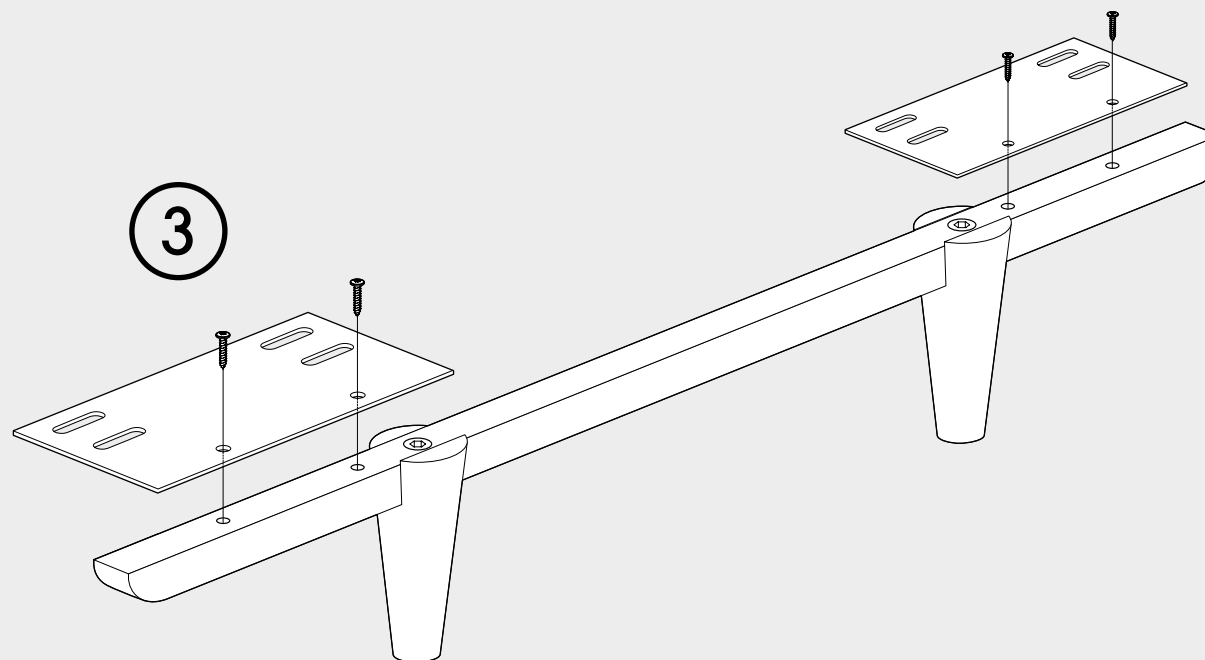

3

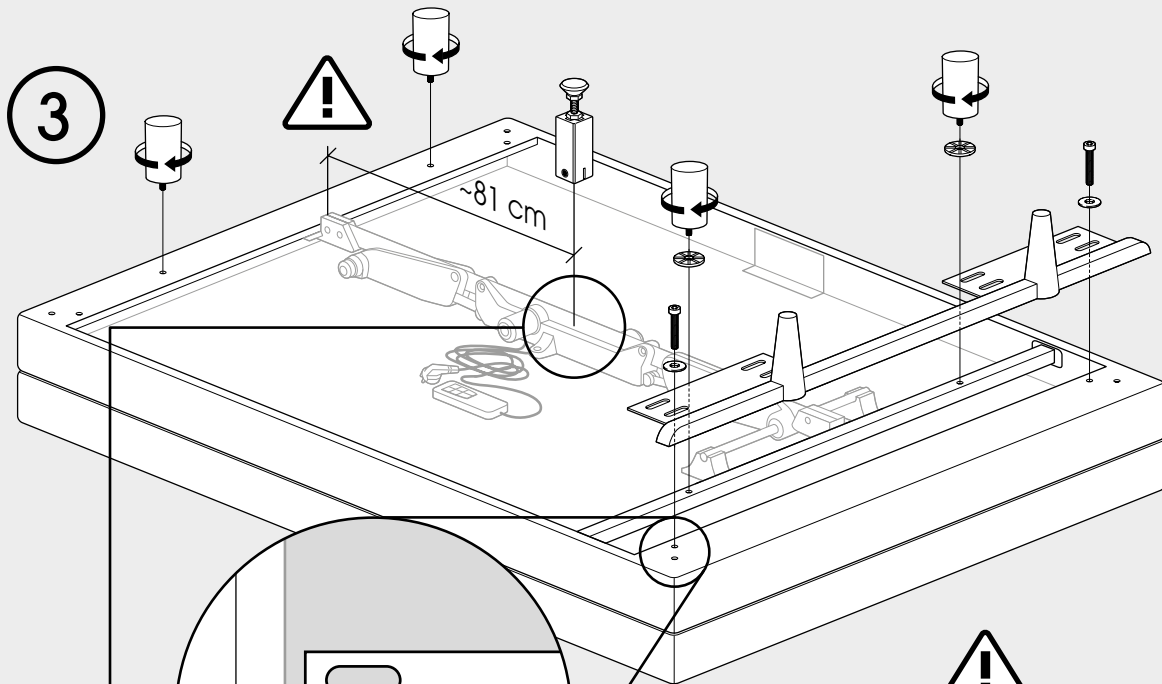

3

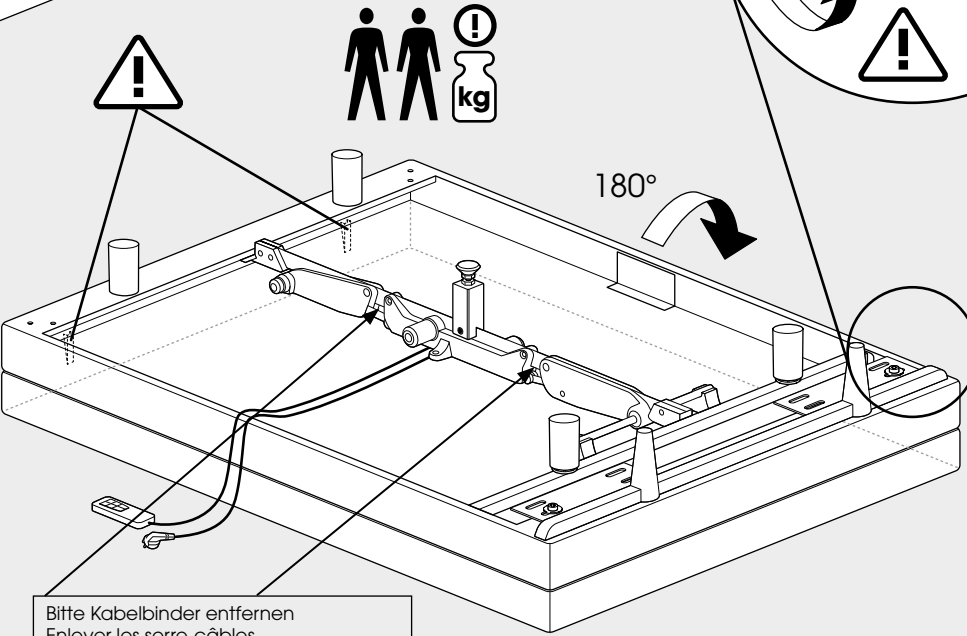
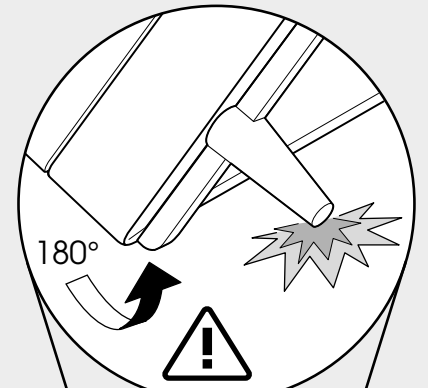
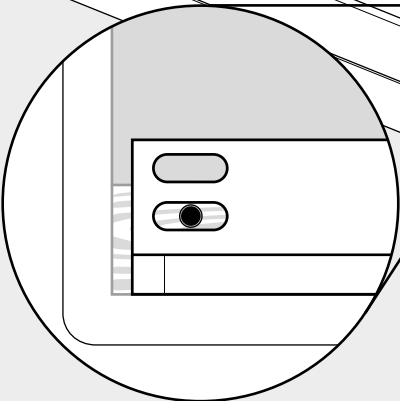

4

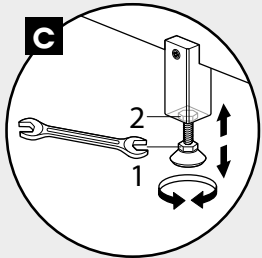
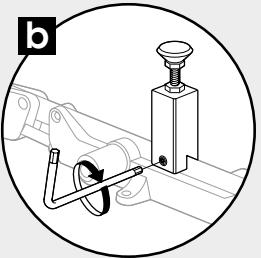
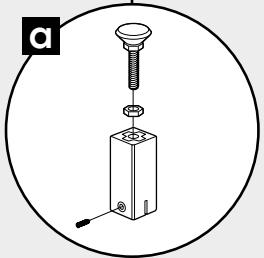

Bitte Kabelbinder entfernen  
 Enlever les serre-câbles  
 Gelieve de kabelbinders te verwijderen  
 Please remove zip ties

5

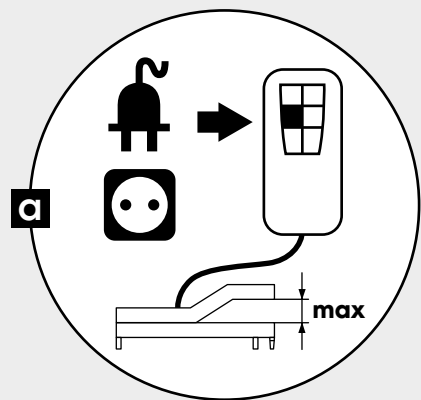

6

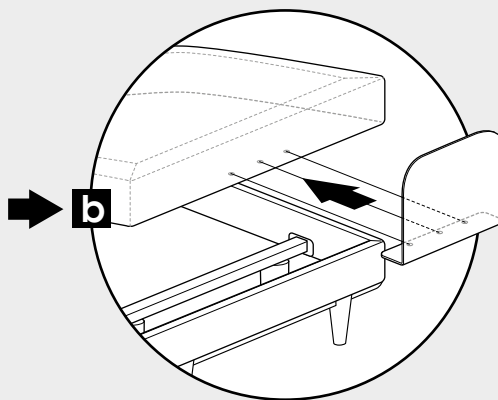

7

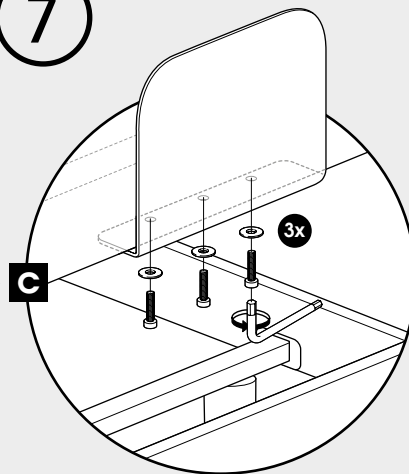

8

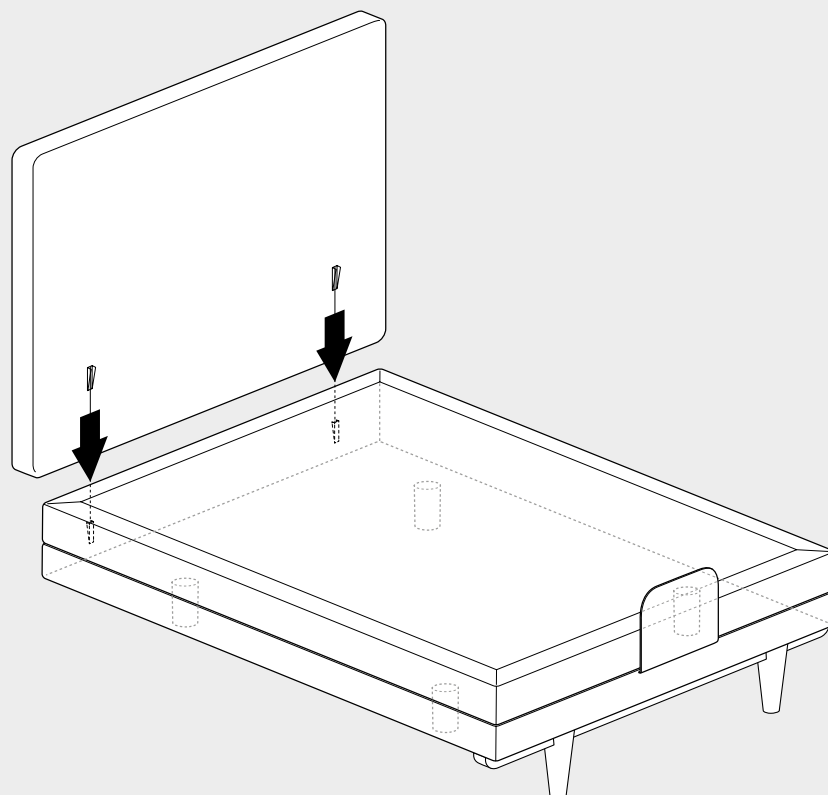

HOLZRAHMEN GESAMT TEIL 1  
 CADRE BOIS TOTAL, PARTIE 1  
 WOOD FRAME DEEL 1  
 WOODEN FRAME PART 1

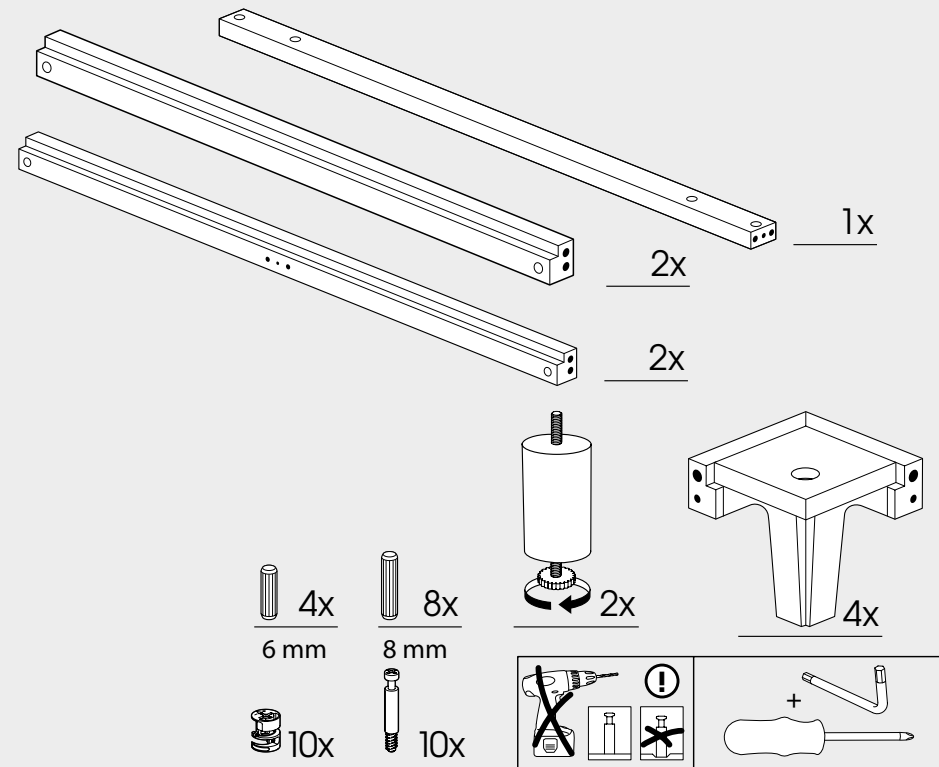
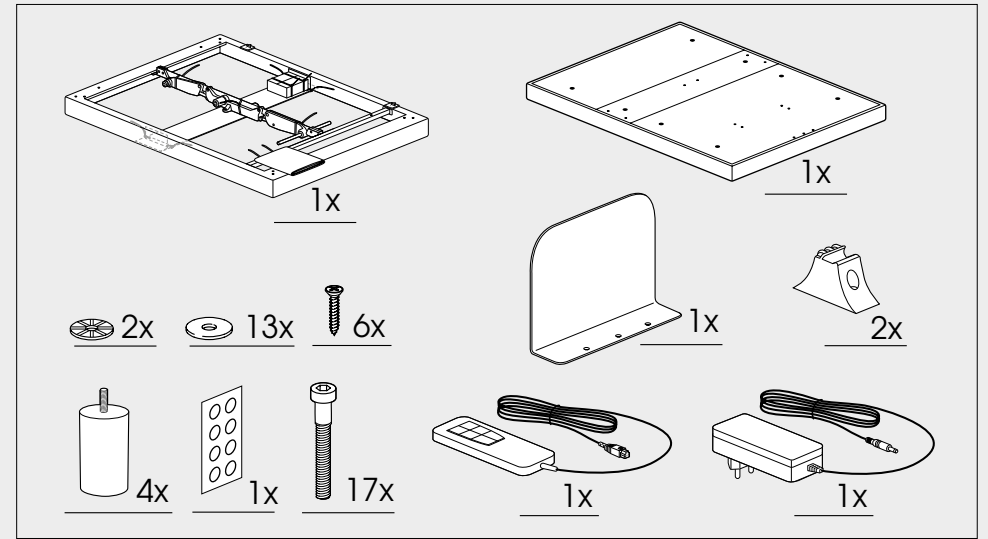
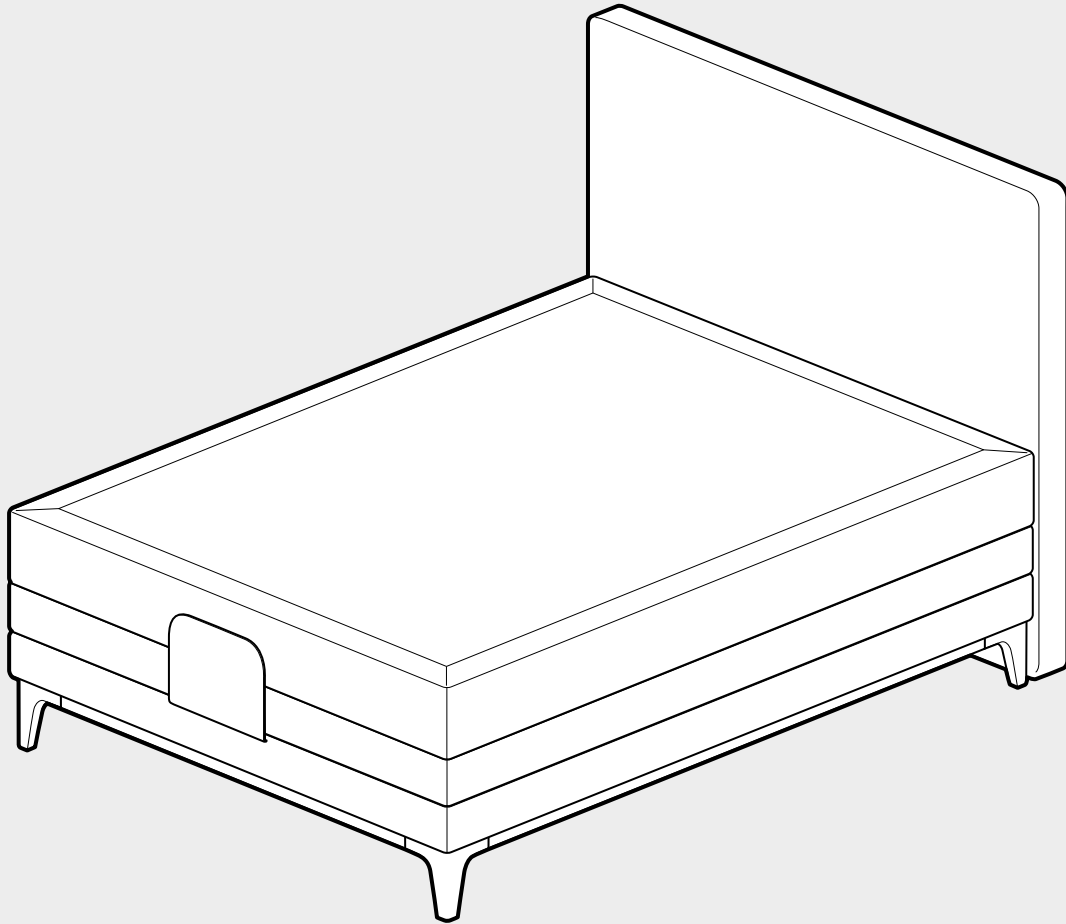

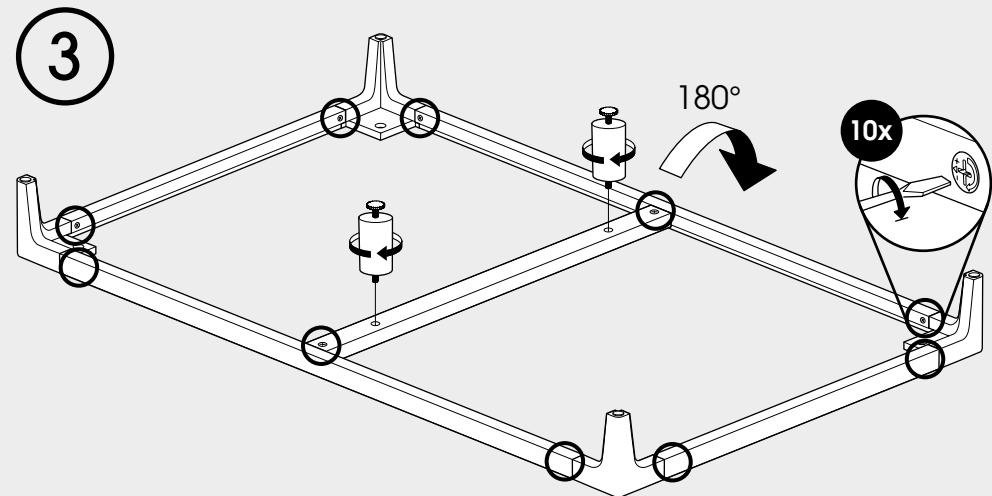
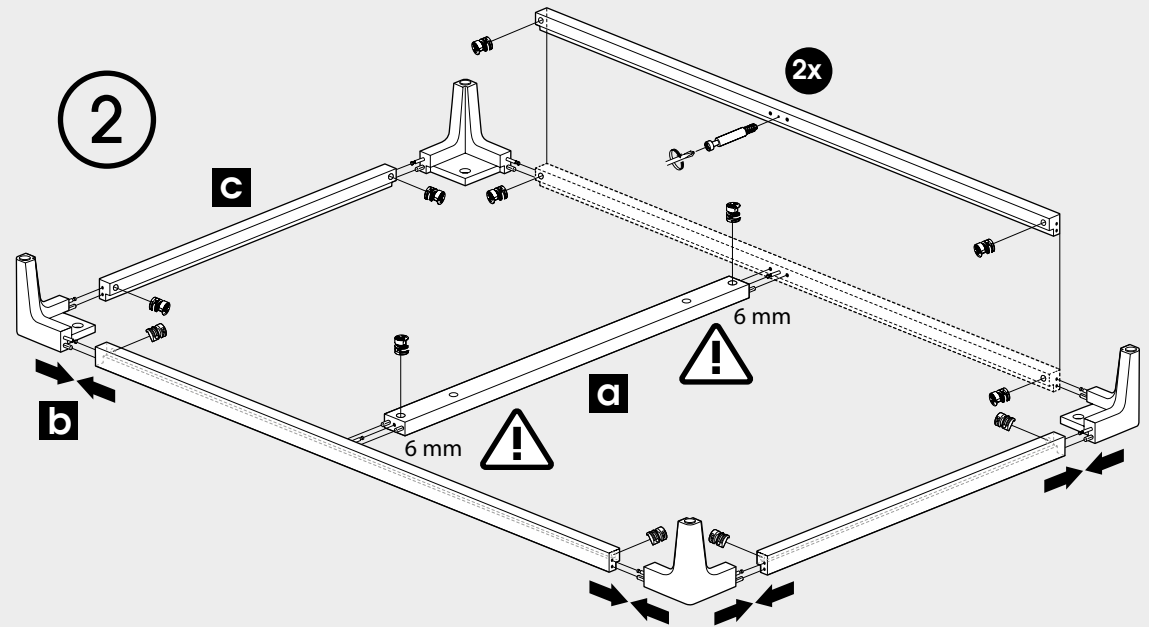
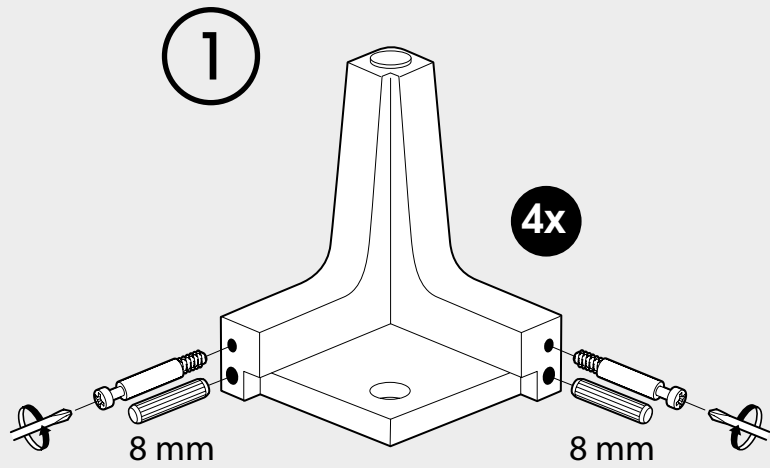

4

Bitte starten Sie mit der Montage der Motorbox analog S.4 bis S.8

Veuillez commencer par le montage du moteur analogique page 4 à page 8

Begin alsjeblift met de montage van de motorbox analoog page 4 tot page 8

Please start with the assembly of the engine box analogue page 4 to page 8

5

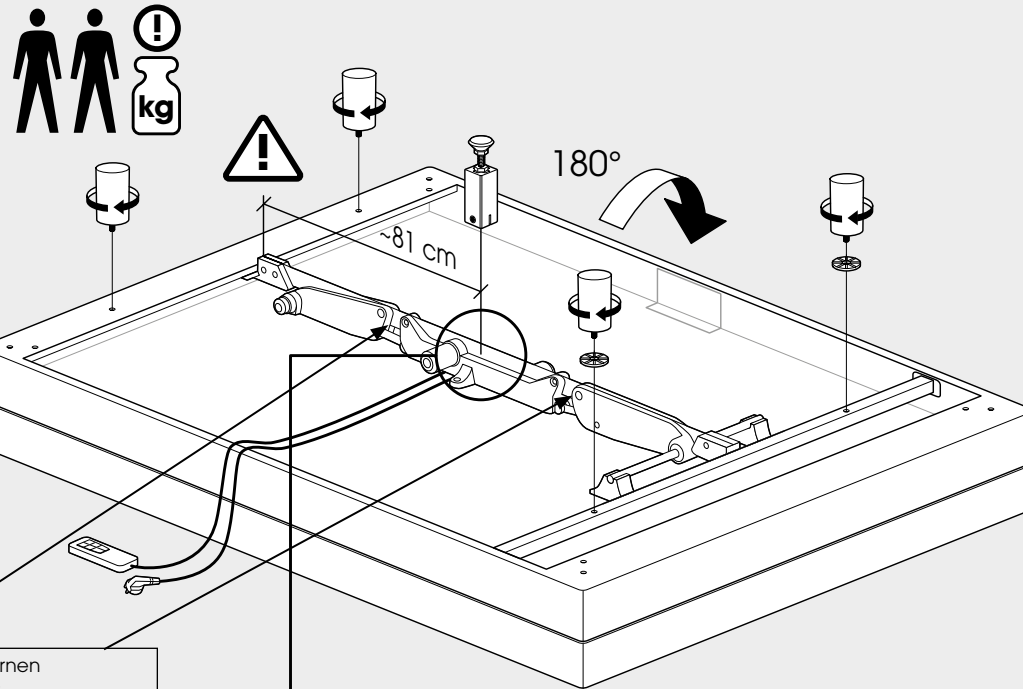

Bitte Kabelbinder entfernen  
Enlever les serre-câbles  
Gelieve de kabelbinders te verwijderen  
Please remove zip ties

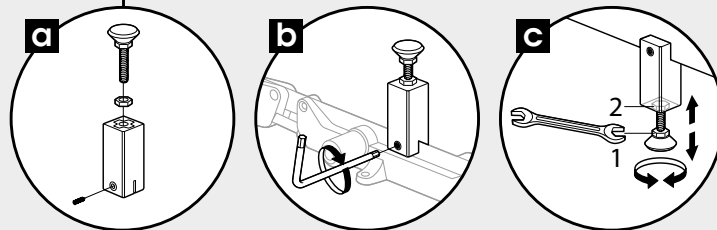

HOLZRAHMEN GESAMT TEIL 2  
CADRE BOIS TOTAL, PARTIE 2  
WOOD FRAME DEEL 2  
WOODEN FRAME PART 2

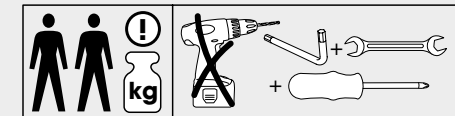
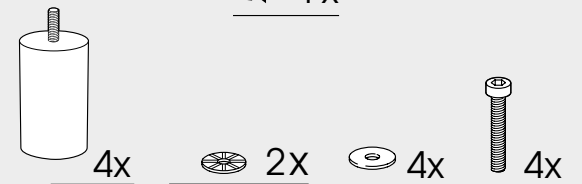
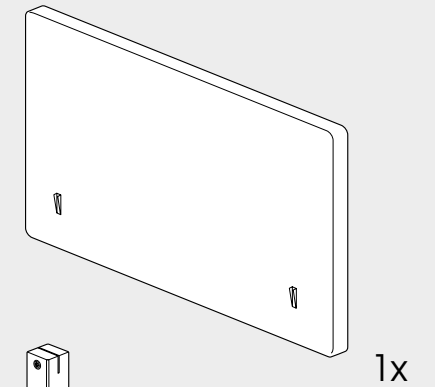
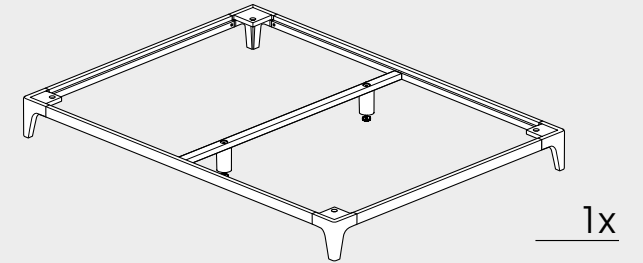

6

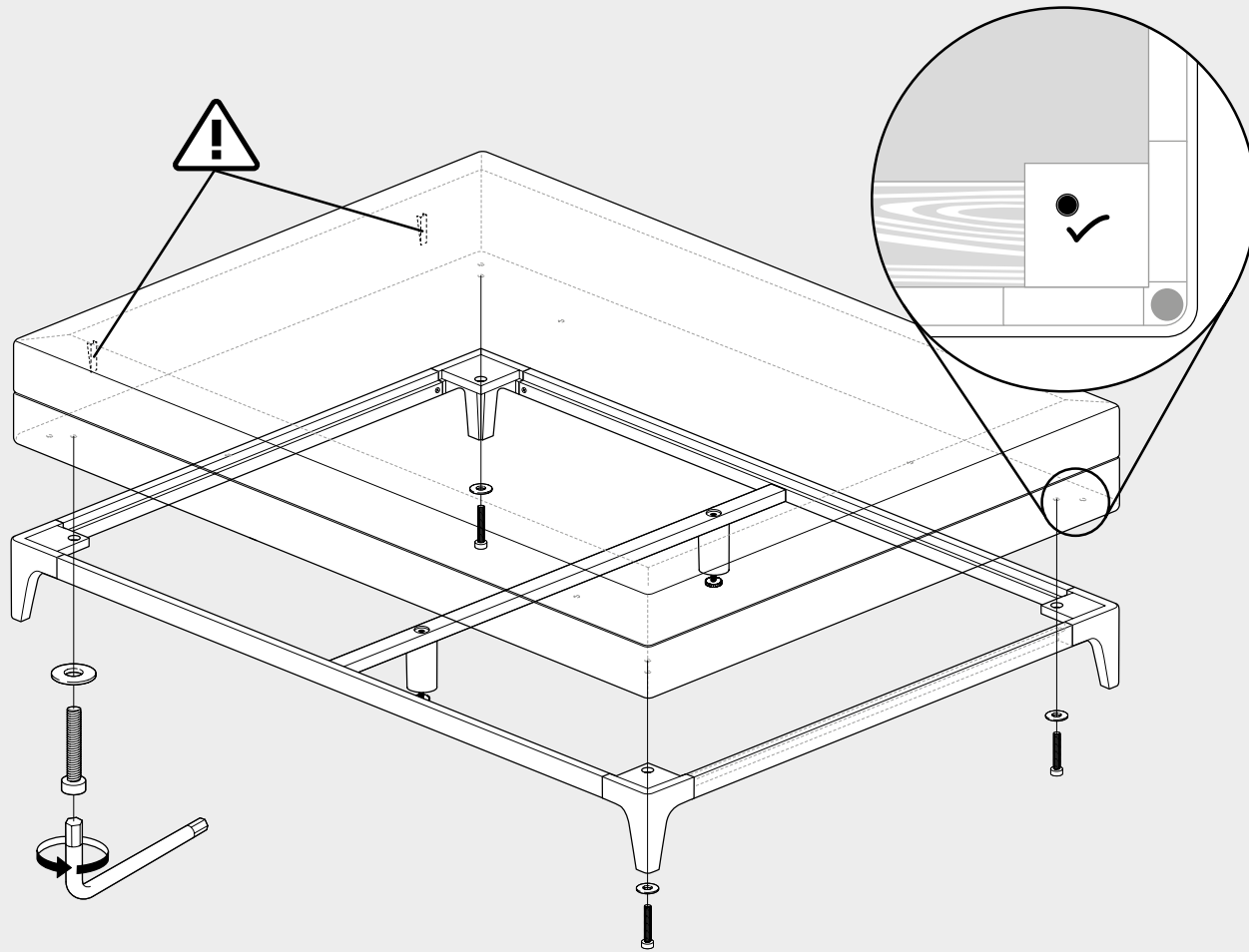



7

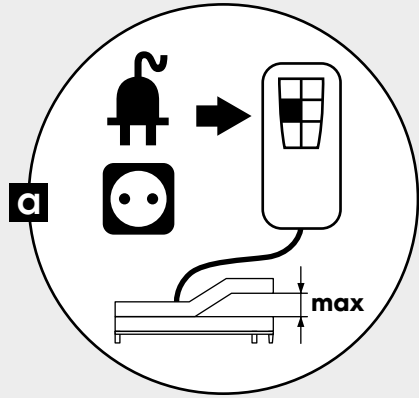

8

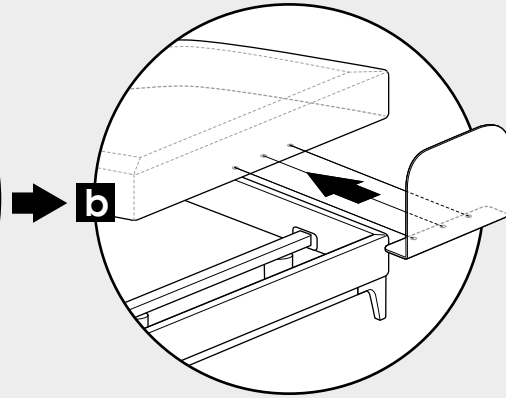

9

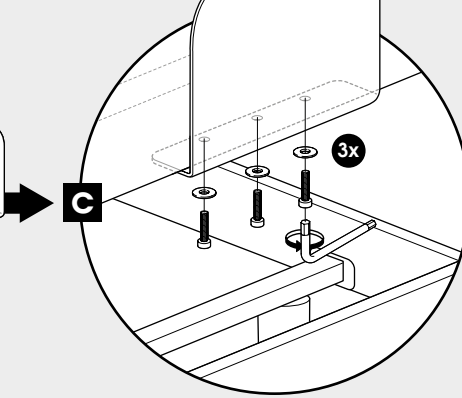

10

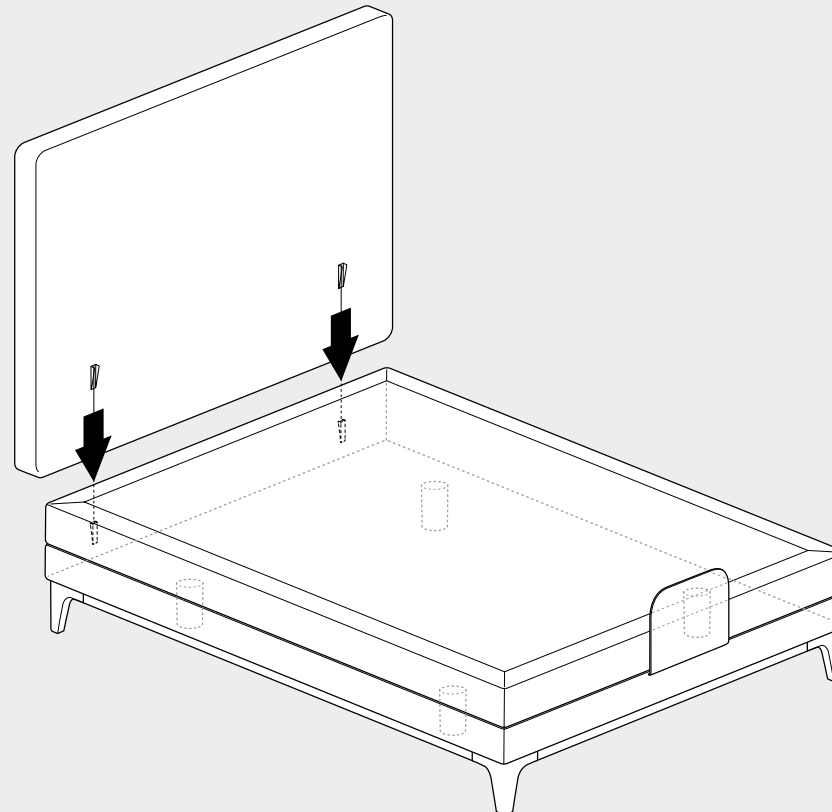

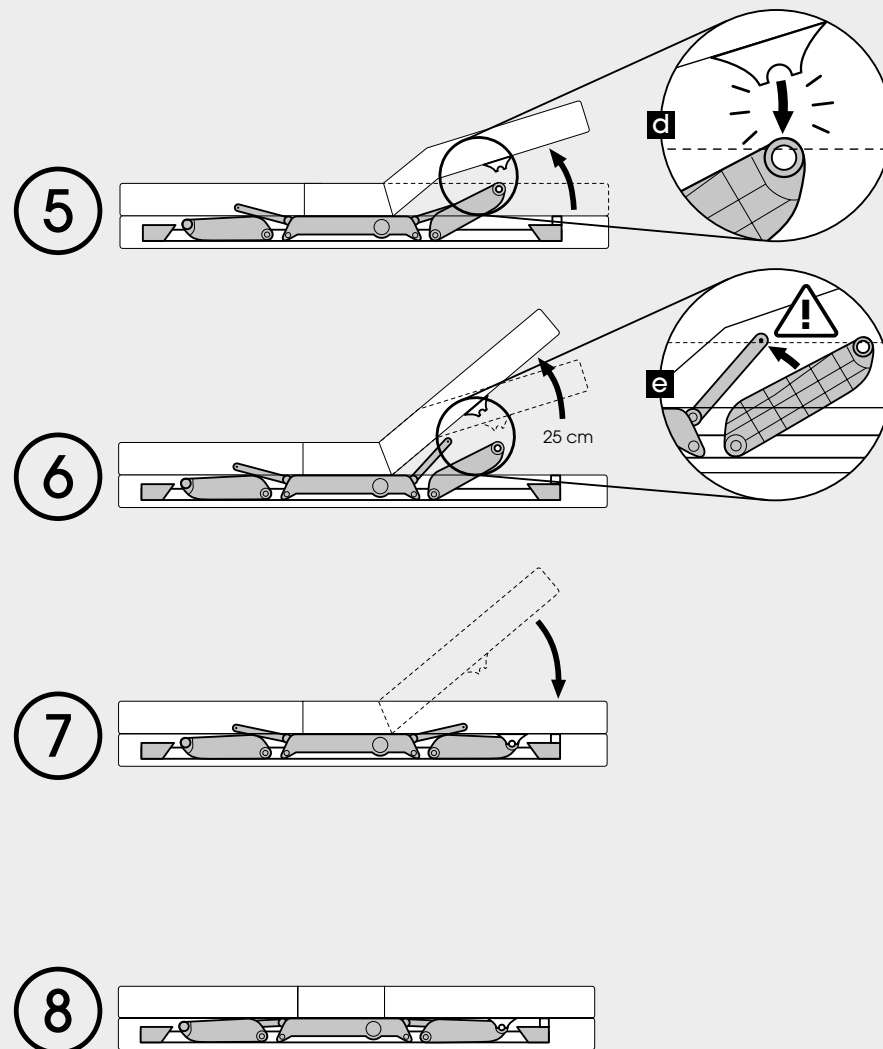
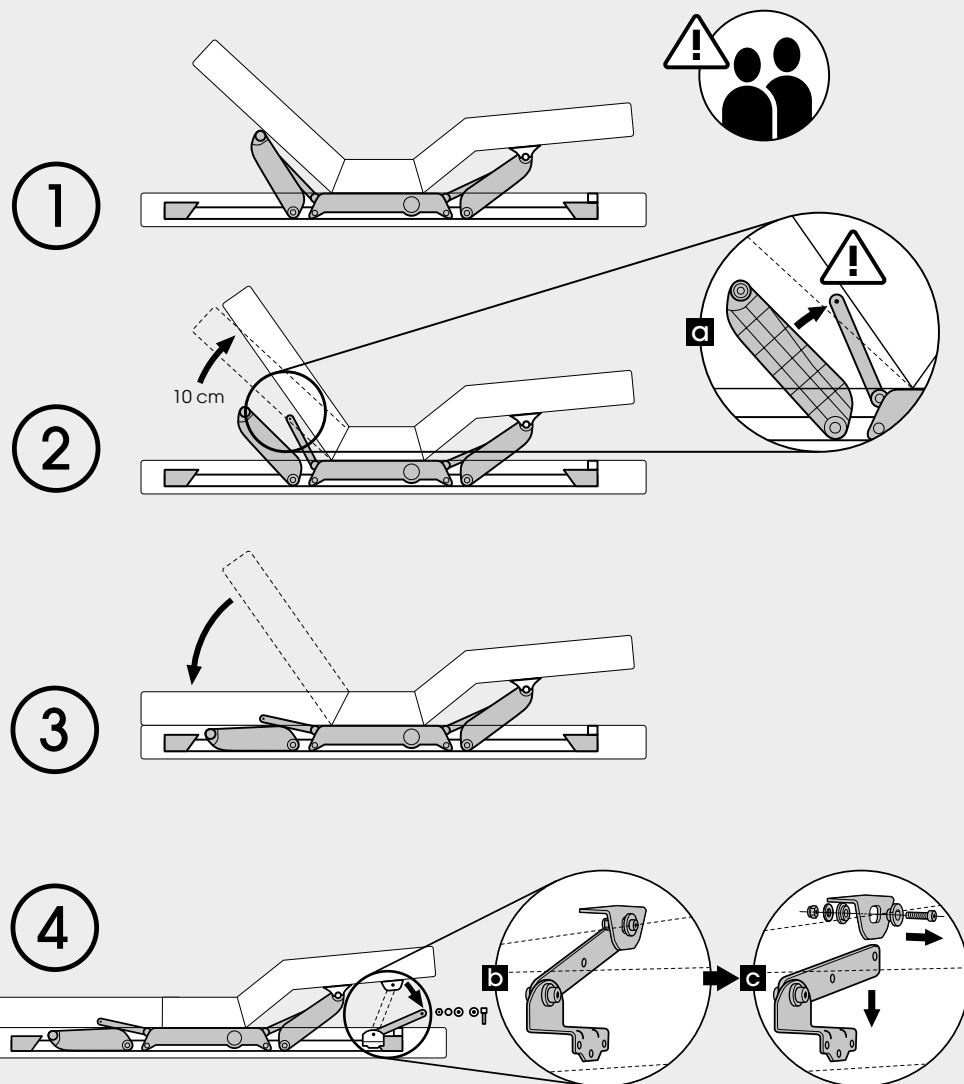

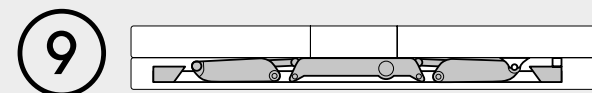
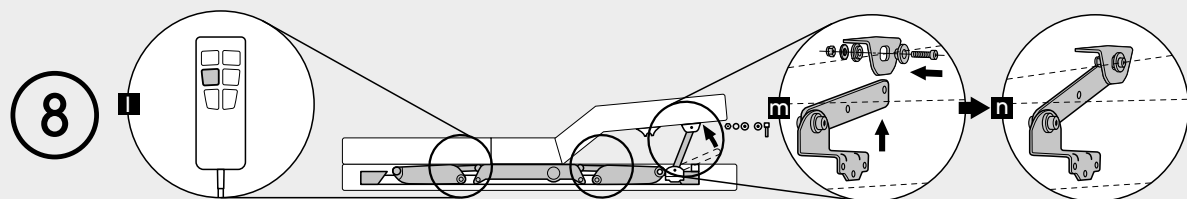
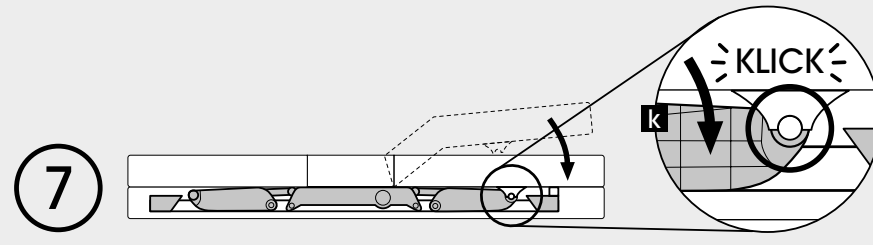
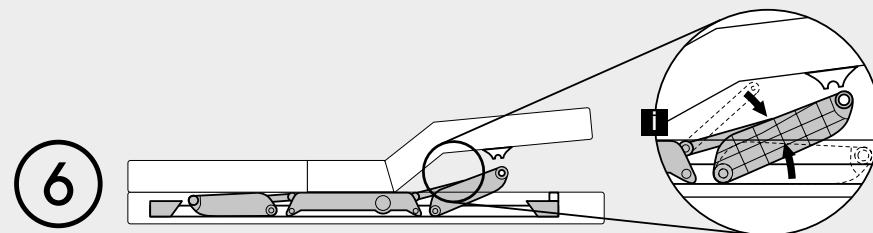
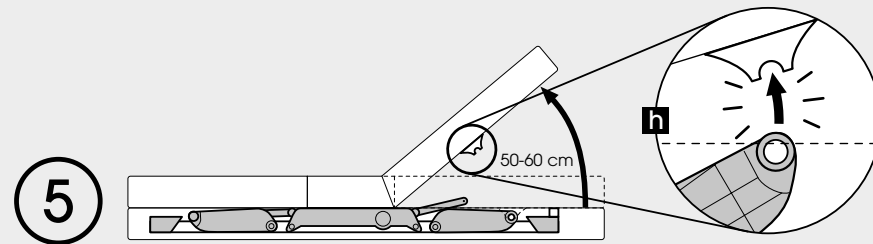
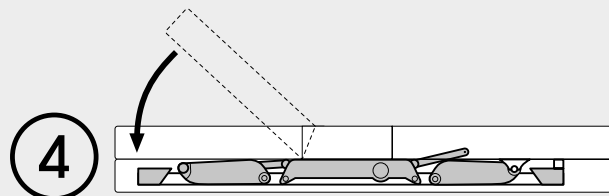
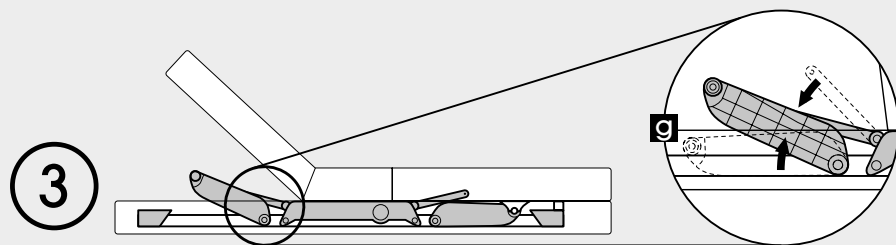
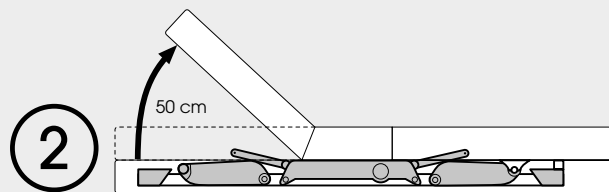
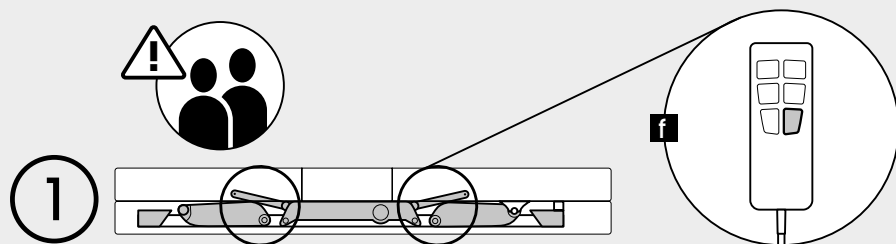

KOPFTEIL MIT REGALEN  
TÊTE DE LIT AVEC ÉTAGÈRES  
HOOFDBORD MET WOOD SIDE STORAGE  
HEADBOARD WITH SHELVES

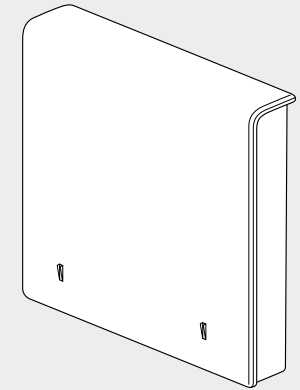
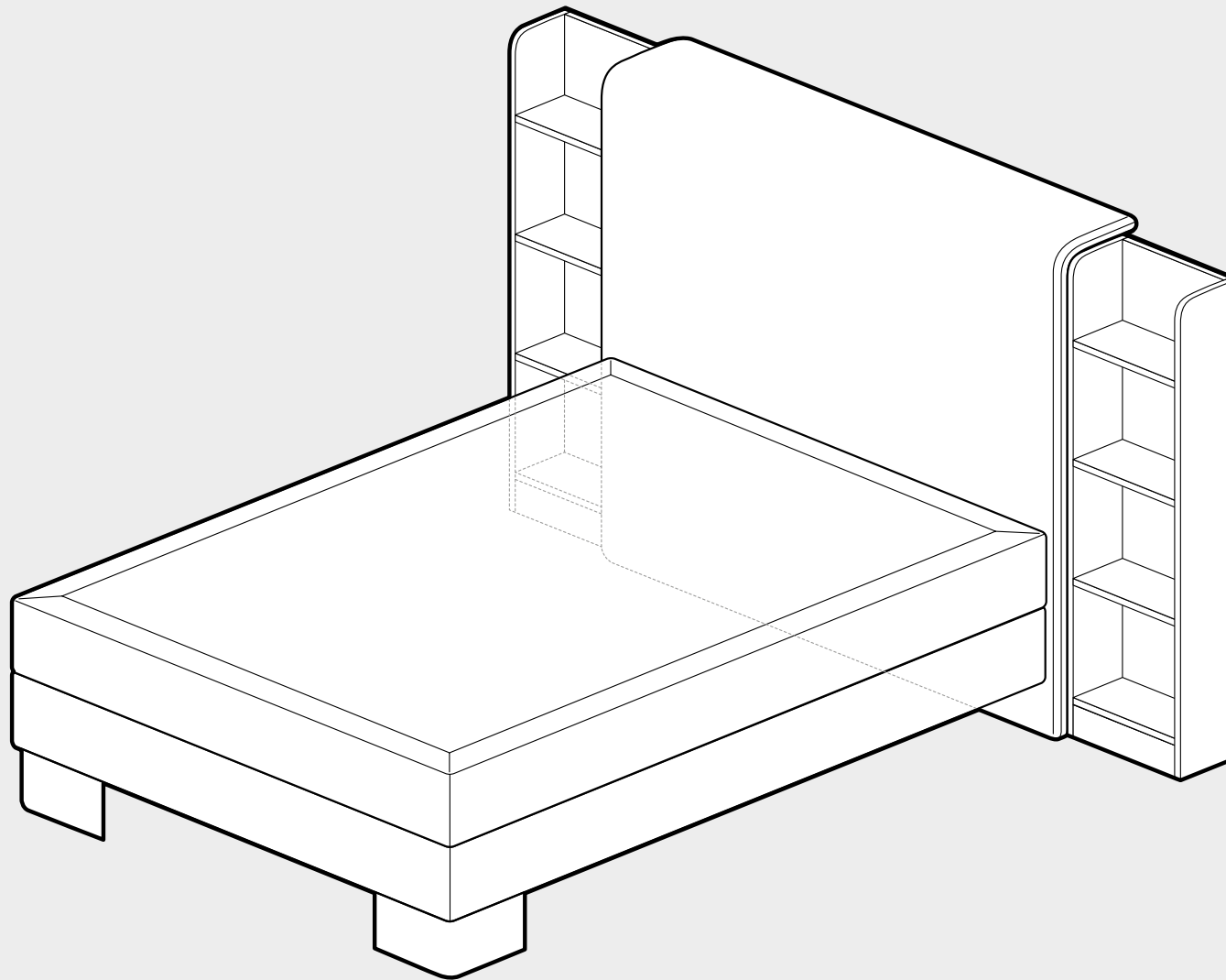

132 cm

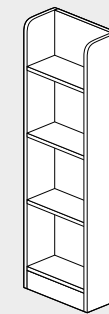

2x



6x



6x

112 cm

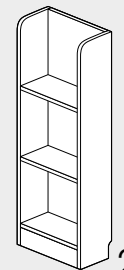

2x



4x



4x

2

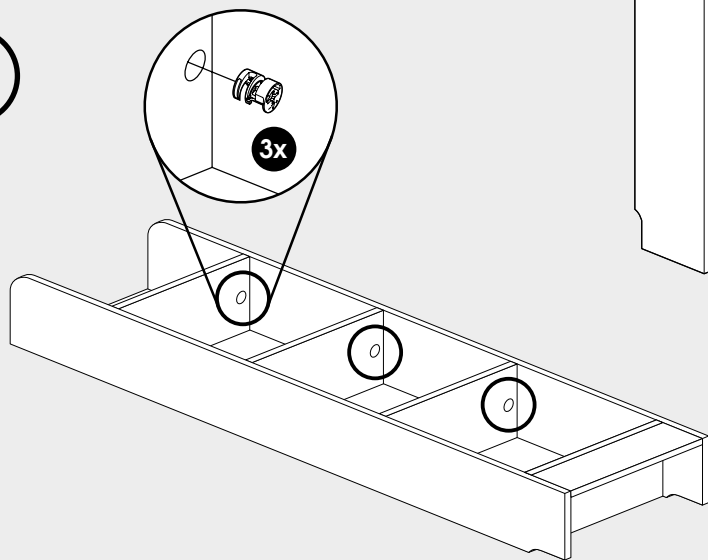

3

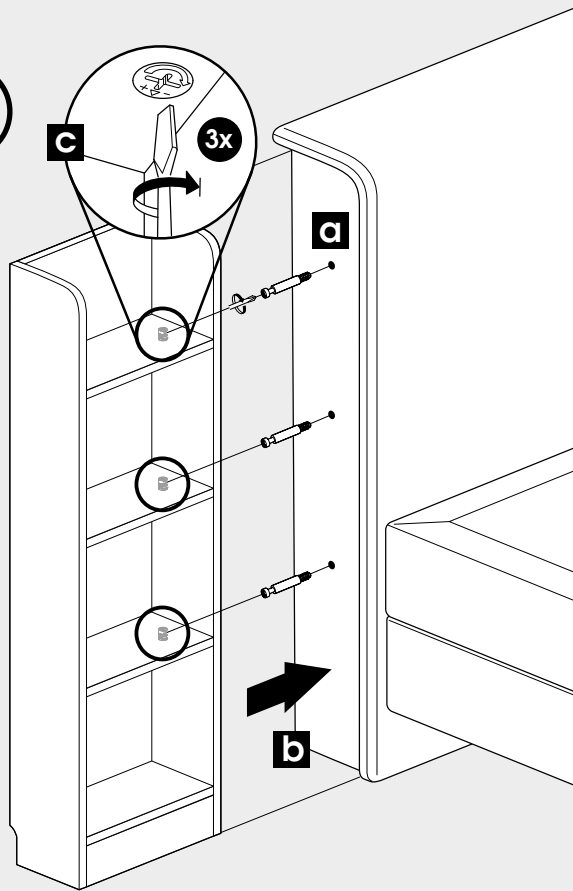

4

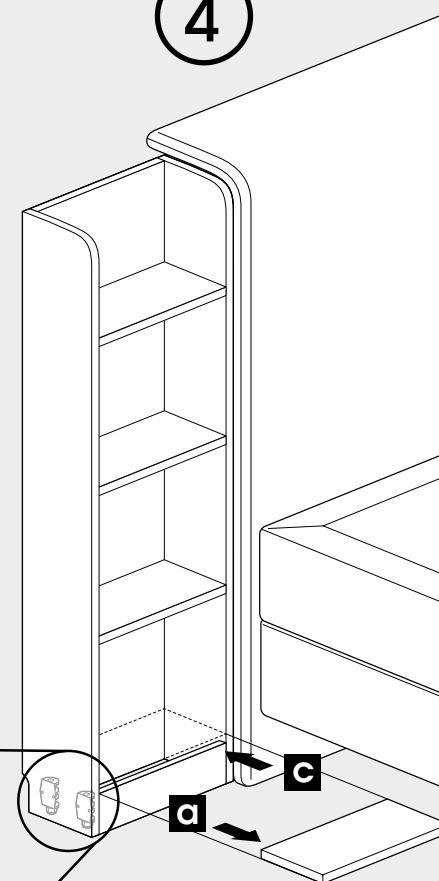

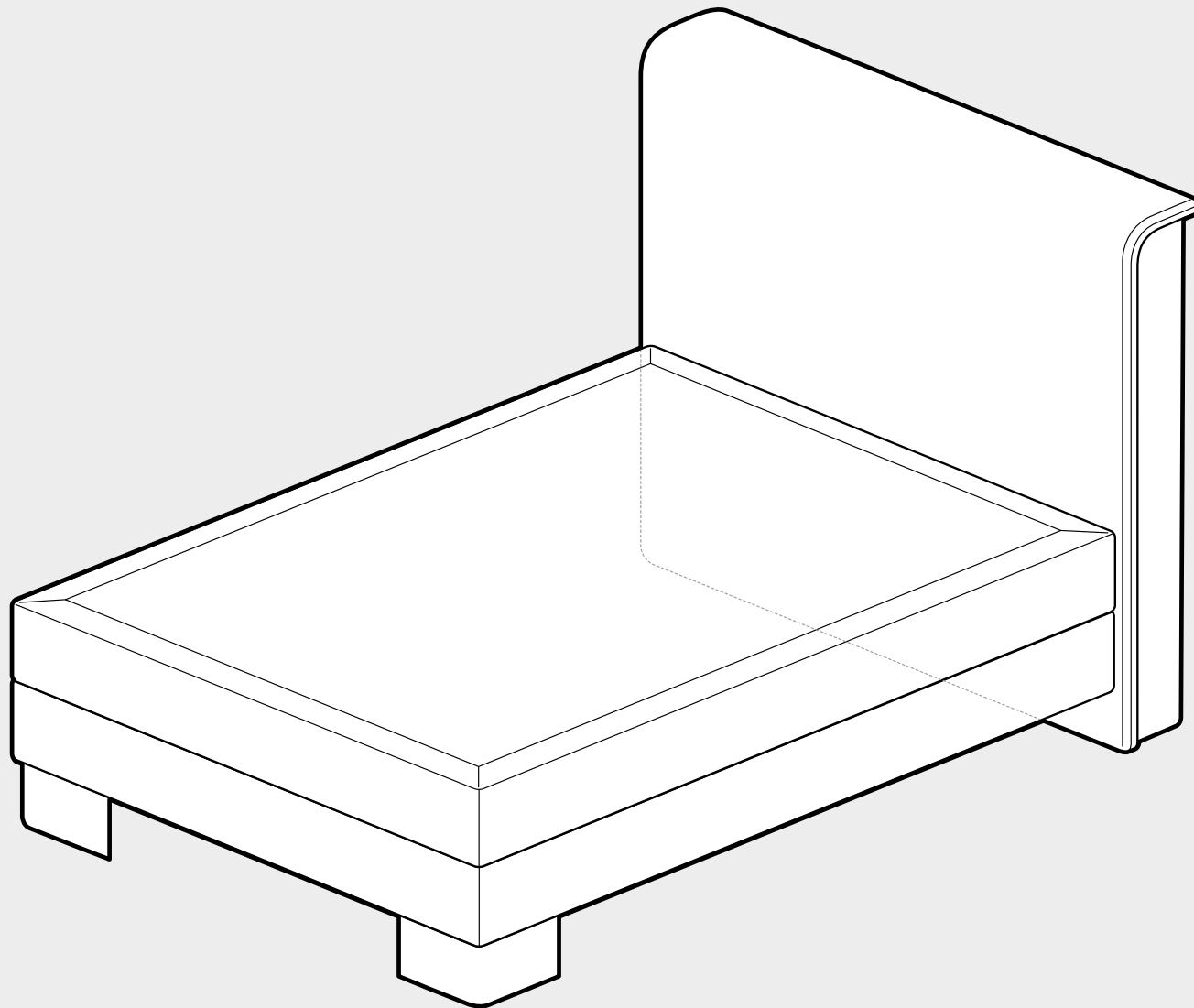

KOPFTEIL MIT SEITENVERBLENDUNGEN  
TÊTE DE LIT AVEC PANNEAUX  
D'HABILLAGE LATÉRAUX  
HOOFDBORD MET ZIJPANELEN  
HEADBOARD WITH SIDE PANELS

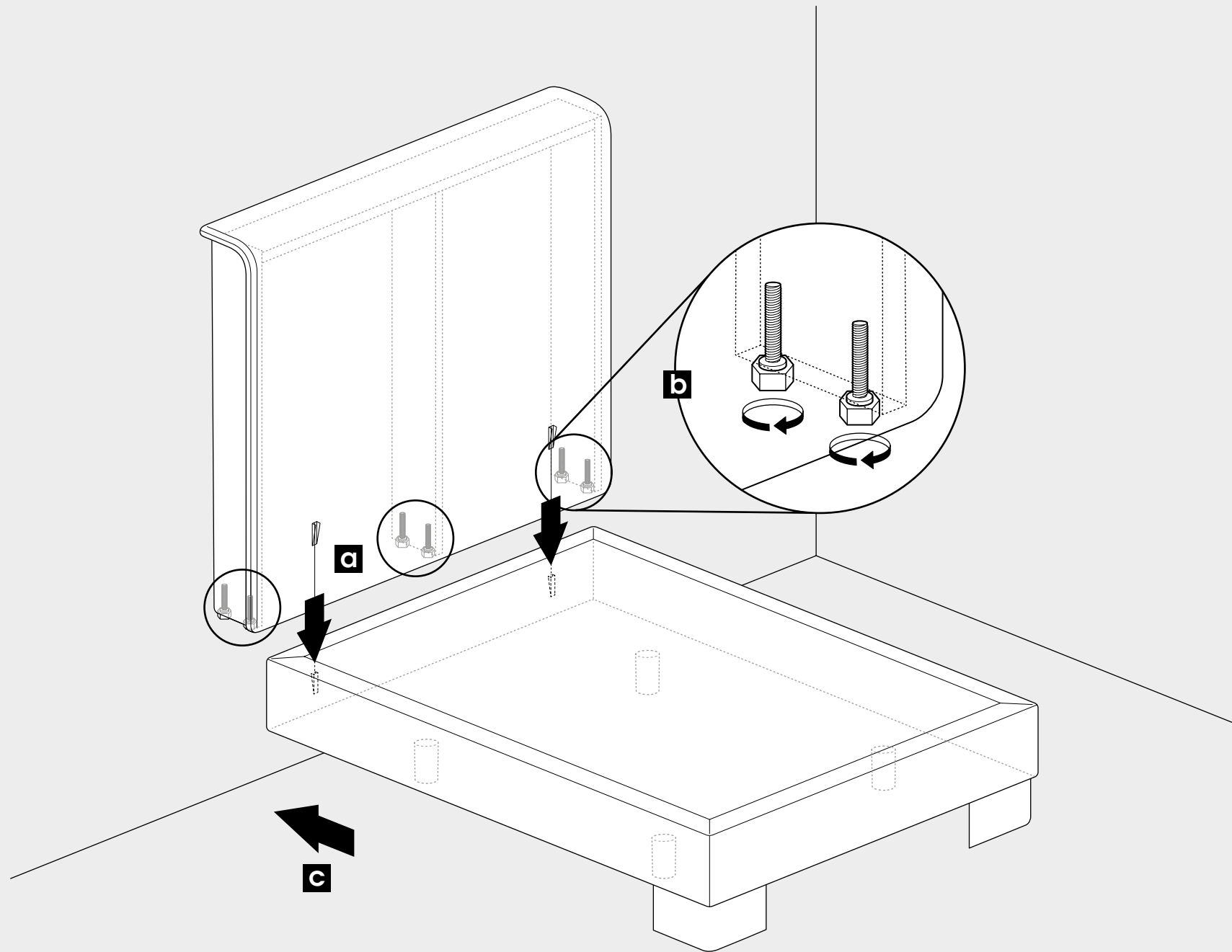

KOPFTEIL MIT SEITENVERBLENDUNGEN // TÊTE DE LIT AVEC PANNEAUX D'HABILLAGE LATÉRAUX  
HOOFDBORD MET ZIJPANELEN // HEADBOARD WITH SIDE PANELS